

# HANN

ART • DRAFTING • PROJECT BASED • SCIENCE • MAKER / STEM • CAREER PREP



TABLES • CASEWORK • STORAGE CABINETS • WORKBENCHES

Building furniture that meets your need is Hann's mission. With a wide variety of furniture and casework for the art room to the workshop, we are likely to have what you are looking for. If not, we'll work with you to design and build the perfect piece.

We are a family owned and operated business that stands behind the products we sell and takes a personal approach to customer service. Include us in your next project and we know you'll appreciate the difference.



**Cory Hann**  
President

<b>Arts &amp; Crafts</b>	.....	<b>2</b>
<b>Drawing &amp; Drafting</b>	.....	<b>12</b>
<b>Project / STEM</b>	.....	<b>18</b>
<b>Science</b>	.....	<b>30</b>
<b>Storage</b>	.....	<b>42</b>
<b>Workbenches</b>	.....	<b>52</b>
<b>Specifications</b>	.....	<b>64</b>

## Contact Us:

P.O. Box 400  
Malta, OH 43758

Phone: 740.962.4885  
Fax: 740.962.4877

sales@hannmfg.com  
www.hannmfg.com

## Construction: Quality Is In The Details...

 Hann-made  
in the USA



With Hann Manufacturing furniture you will never have to say, “...they don’t build them the way they used to.” We use time tested methods and materials to construct furniture that will hold its own in the classroom year after year. Hallmarks of quality such as mortise and tenon joinery and dovetailing are present in every piece we build.

We use solid hard maple or red oak in basic structural furniture components such as framing, aprons, legs and spreaders. These North American hardwoods are known for their strength and durability. Hann uses full face frame construction. Face frames are mortise and tenoned, glued and stapled together to form a rigid structural component. Veneercore panels used for ends and interior components are routed into the face frame and each other resulting in sturdy, interlocking furniture and casework.

There are no assembly lines at Hann Manufacturing. Each piece is built one at a time by experienced hands allowing us to devote the necessary time and attention to the details that truly matter. Yes, we build it like they used to!

### Hann Can! <sup>SM</sup>

We can adapt a standard product to meet your specifications. Whether it is a minor adjustment or developing a unique piece for a special need, Hann Can! deliver your custom product without the custom price!



**Art Table Series**

Multi-purpose art tables in a variety of base and top combinations to best suit your classroom requirements. These tables are built to last with thick solid hard maple components. The upper and lower spreaders are connected to the leg panels with bolt reinforced mortise and tenon joints. A total of six draw bolts and a tall lower spreader provide excellent rigidity and maintainability. Adjustable floor glides are included.

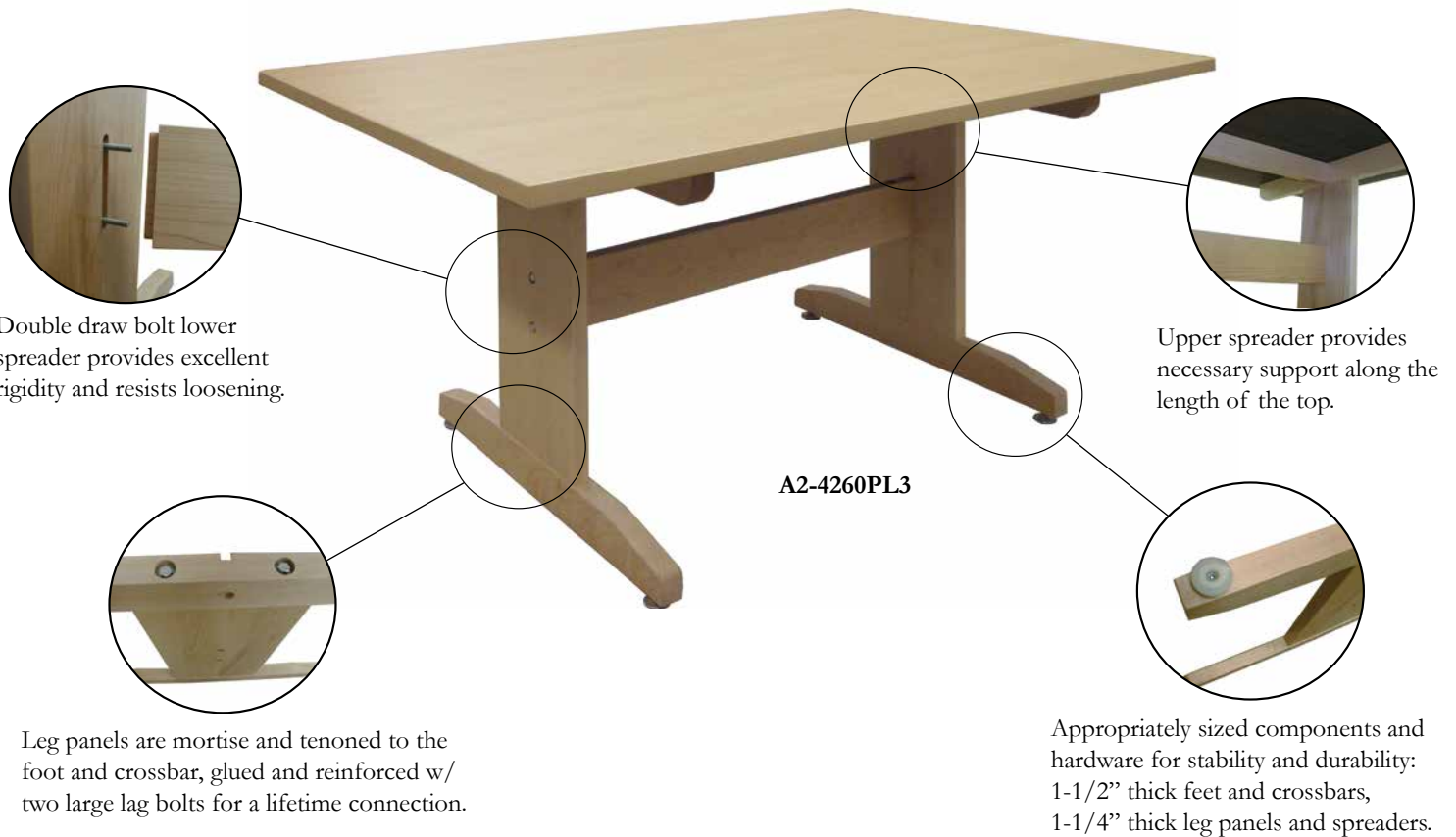

**A2-4260PL3**



**A1-4260M**



**A2-4260PLA**



A2-4260PL3-BS



A2-3060M

**Model Number Format: (Base Style) - (Top Size)(Top Type) - (Options)**

**Base Style**

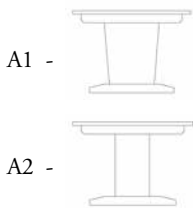

A1 -

A2 -

**Top Size**

- 24" x 60" - '2460'
- 30" x 60" - '3060'
- 42" x 60" - '4260'
- 42" x 72" - '4272'

**Top Types**

- 1-1/4" Thick 'Maple Grain' Pattern HPL w/ 3mm Edgeband - 'PL3'
- 1-1/4" Thick 'Maple Grain' Pattern HPL w/ Urethane Edge - 'PLA'
- 1-1/4" Thick Black HPL w/ 3mm Edgeband - 'PLBK3'
- 1-3/4" Thick Solid Hard Maple - 'M'

**Options**

- Bookshelves - 'BS'
- Tote Trays - 'TT'
- 26" Height - '26'

**Example Model Numbers:**

- A1-4260M - 'A1' base, 1-3/4" x 42" x 60" hard maple top, 30" overall height
- A2-3060M - 'A2 base', 1-1/4" x 30" x 60" hard maple top, 30" overall height
- A2-4260PL3-BS - 'A2 base', 1-1/4" x 42" x 60" 'maple grain' patterned HPL top w/ 3mm PVC edgeband, 30" overall height, includes bookshelves
- A2-4272PLBK3-26 - 'A2 base', 1-1/4" x 42" x 72" black HPL top w/ 3mm PVC edgeband, 26" overall height
- A2-4260PLA - 'A2 base', 1-1/4" x 42" x 60" 'maple grain' patterned HPL top w/ urethane edging, 30" overall height



A2-4260PLBK3



A2-3060PL3



A2-4260PLBK3-36



A2-4272M-36D

### Studio Art Table Series

Our studio series offers standing height (36" high) tables with the option of drawer storage and a lower shelf. The table base features the same solid hard maple materials and mortise and tenon construction as our standard art tables series. Available with multiple top types and sizes. The storage drawer option includes (2) drawers at both the front and rear of the table. The inside dimensions of the drawers is approximately 2" x 14"W x 15"D for the 42" x 60" top size and is approximately 2" x 19"W x 15"D for the 42" x 72" top size.

**Model Number Format: A2 - (Top Size)(Top Type) - 36(Options)**

**Top Size**

42" x 60" - '4260'  
42" x 72" - '4272'

**Top Types**

1-1/4" Thick 'Maple Grain' Pattern HPL w/ 3mm Edgeband - 'PL3'  
1-1/4" Thick Black HPL w/ 3mm Edgeband - 'PLBK3'  
1-3/4" Thick Solid Hard Maple - 'M'

**Options**

Drawers - 'D'  
Shelf - 'S'

**Example Model Numbers:**

**A2-4272M-36D** - 1-3/4" x 42" x 72" hard maple top, 36" overall height, includes drawer storage

**A2-4260PLBK3-36** - 1-1/4" x 42" x 60" black HPL top, 36" overall height

**A2-4272PL3-36DS** - 1-1/4" x 42" x 72" 'maple grain' patterned HPL top, 36" overall height, includes drawer storage and lower shelf



A2-4272PL3-36



A2-4272PL3-36DS



**Crafts Bench**

A sturdy bench w/ storage for large or small items and a hard maple top. The base consists of two steel base cabinets placed back-to-back. Each cabinet includes a locking handle and adjustable shelf. Cabinets measure 36”W x 21”D x 31”H. The 2-1/4” thick hard maple top measures 64”W x 54”D. Overall height is 33-1/4”.  
**Model DD4-0V**



**Art Table with Lower Shelf**

The base of this unit is constructed of solid hard maple. Spreaders are joined to the legs on all sides of the table via bolt-reinforced mortise and tenon joinery. The lower shelf is comprised of solid hard maple slats which can support heavier objects while leaving spaces in between so that debris can fall through to the floor. The table can alternatively be ordered with a solid plywood shelf. The hard maple top measures 2-1/4” x 64”W x 54”D. Overall height is 32”.

**Model WL4-0V**



**STX-4848M**



**Four Student Table**

Sturdy multi-purpose table features intersecting lower cross bracing which provides rock solid stability while allowing for leg room on all four sides. Mortise and tenon joints with draw bolts. Top choices include a 1-3/4” x 48” x 48” hard maple top or a 1-1/4” x 48” x 48” ‘maple grain’ patterned HPL top. Available in an overall height of 30” or 36”. Locking casters optional.

- Model STX-4848M** 30” H, Hard Maple Top, No Casters
- Model STX-4848M-C** 30” H, Hard Maple Top, w/ Casters
- Model STX-4848M-36** 36” H, Hard Maple Top, No Casters
- Model STX-4848M-36C** 36” H, Hard Maple Top, w/ Casters

- Model STX-4848P** 30” H, HPL Top, No Casters
- Model STX-4848P-C** 30” H, HPL Top, w/ Casters
- Model STX-4848P-36** 36” H, HPL Top, No Casters
- Model STX-4848P-36C** 36” H, HPL Top, w/ Casters

**Adjustable Height Table**

Perfect for any classroom or office application that requires flexibility or ADA accessibility. A smooth operating, sealed hydraulic system raises or lowers the table by means of an easy to use hand-crank pump mechanism which requires very little effort. Hydraulic cylinders are concealed within telescoping die-cast aluminum legs. Operating handle folds neatly out of the way when not in use. Lift capacity is 500 pounds. The table can be adjusted to any height between 27” and 35”.

Size	1-1/4” Chemsurf	1-3/4” Hard Maple	1-1/4” HPL
30 x 60	AH530C	AH530M	AH530P
30 x 72	AH630C	AH630M	AH630P

### Art Workstation Series

These workstations serve as excellent project centers providing both a large, sturdy work surface as well as a variety of storage options. All workstations are available with either a 2-1/4" x 54" x 64" hard maple top or a 1-1/4" x 54" x 64" 'maple grain' patterned HPL top. The base of the workstation consists of two cabinets placed back-to-back. Base cabinets are built using heavy-duty solid hard maple face frame construction. The top overhangs the base cabinets by roughly 9" on all sides allowing for seating around the entire perimeter of the workstation. Overall height is 33-1/4".



Shown w/ optional casters



AWS-2D2T



Opposite Side

### Crafts & Project Workstation

The same cabinet is used on both sides of this unit. Each cabinet has storage for (2) tote caddies (included) in the upper section and (2) large drawers for tools and supplies in the lower section. The drawers measure 29"W x 17"D x 2-3/4"H (I.D.).

**Model AWS-2D2T** Hard maple top  
**Model AWS-2D2T-C** Hard maple top, casters

**Model AWS-2D2T-P** HPL Top  
**Model AWS-2D2T-P-C** HPL Top, casters



AWS-3331



Opposite Side

### Art & Printmaking Workstation

One side of this workstation features a 6-drawer cabinet for paper and tool storage. Each drawer measures 29"W x 23"D x 1-3/4"H (I.D.). The opposite side of the unit is a double-door cabinet with an adjustable shelf for flexible storage of larger project items.

**Model AWS-3331** Hard maple top  
**Model AWS-3331-C** Hard maple top, casters

**Model AWS-3331-P** HPL Top  
**Model AWS-3331-P-C** HPL Top, casters



AWS-3332U-P



Opposite Side

### Art & Printmaking Workstation

One side of this workstation features a 6-drawer cabinet for paper and tool storage. Each drawer measures 29"W x 23"D x 1-3/4"H (I.D.). The cabinet on the opposite side of the unit includes a double-door cupboard area in the upper section and two storage drawers below.

**Model AWS-3332U** Hard maple top  
**Model AWS-3332U-C** Hard maple top, casters

**Model AWS-3332U-P** HPL Top  
**Model AWS-3332U-P-C** HPL Top, casters



### Mobile Paper Storage

This mobile unit features five large drawers which are great for storing paper and supplies. Drawers measure 41"W x 24"D x 2-3/4"H. The cabinet moves on lockable heavy duty casters and includes a Fiberesin top. Overall size is 48"W x 28"D x 35"H.  
**Model MPS-4828**



### Portfolio Storage Cabinet

Store portfolios or individual works of art in this flexible vertical storage cabinet. The cabinet is built using our heavy duty solid hard maple face frame construction. The top is 3/4" thick Fiberesin and the dividers are 1/4" hardboard. Each divider is removable to allow for storage of thicker items as necessary. Default spacing allows for (13) separate storage slots, each measuring 2-1/4"W x 29"D x 24-3/4"H. Overall cabinet dimensions are 39"W x 30"D x 33"H.

**Model OBC-39PST**



### Mobile Paper and Slot Storage

This mobile unit features five large drawers which are great for storing paper and supplies. Drawers measure 41"W x 24"D x 2-3/4"H. The cabinet moves on lockable heavy duty casters and includes a Fiberesin top. Overall size is 48"W x 24"D x 35"H.  
**Model MPS-OBC-COMBO**



### Paper Storage Cabinet

Includes seven large pull-out shelves. Base is sturdily constructed of hard maple framing with mortise and tenon glue joints. Shelves are mounted on ball bearing slides and have 3" high side and back stops. Available tops include 1-1/4" thick plastic laminate and 1-3/4" thick hard maple. Natural finish. Overall size of the cabinet is 47"W x 29"D x 36"H.

**Model BC-170M** - w/ maple top.

**Model BC-170P** - w/ HPL top.

### Segmented Art Storage Series

Select the storage you want with this series of art storage cabinets. Choose up to (3) storage segments and arrange them in any order. The cabinet features thick solid hard maple face frame construction. Available segments include double-door cupboard, open single shelf, open three shelf, three drawers, open pullout shelves, and portfolio storage. Cabinet is 39"W x 30"D and the overall height depends upon segments selected.

Possible combinations include:

Bottom segment: double-door cupboard, Middle: open three shelves, Top: portfolio storage. Overall height is 77-1/4".  
**Model SASC-31-38-39**

Bottom segment: portfolio storage, Middle: open three shelves, Top: double-door cupboard. Overall height is 77-1/4".  
**Model SASC-39-38-31**

Bottom segment: double-door cupboard, Middle: open pullout shelves, Top: portfolio storage. Overall height is 77-1/4".  
**Model SASC-31-37-39**

Bottom segment: portfolio storage, Middle: open pullout shelves, Top: double-door cupboard. Overall height is 77-1/4".  
**Model SASC-39-37-31**

Bottom segment: three drawers, Middle: open pullout shelves, Top: double-door cupboard. Overall height is 73".  
**Model SASC-30-37-31**

Bottom segment: portfolio storage, Top: portfolio storage. Overall height is 59-3/4".  
**Model SASC-39-39**



**SASC-31-37-39**



**SASC-39-38-31**



### Mobile Art Center

Hann's mobile art center provides a variety of storage options for art supplies. The unit includes four drawers and a cupboard with four shelves. Furnished with two large tote trays and locking casters. Lipped Fibersin top keeps objects from falling off while the unit is in motion. Natural finish. Overall size is 36"W x 24"D x 37-1/4"H.  
**Model AC-137M**



### Portable Clay Cart

A portable clay cart constructed of hard maple plywood and furnished with locking casters. Features an anti-slam lid stay device. Includes removable plastic tub for clay storage. Overall size is 16-1/2"W x 22"D x 21-1/4"H.  
**Model CC-7**



### Clay Unit

This ceramics project center features a three-drawer cabinet, single door storage cabinet with adjustable shelf, and CC-7 portable clay cart. The maple grain patterned plastic laminate top (72" x 30" x 1-1/4") provides a smooth, flat work surface. The base cabinets feature heavy duty face frames with mortise and tenon construction. Overall size is 72"W x 30"D x ~30"H.  
**Model CC-2A**

Same as CC-2A, except w/ 1-3/4" thick hard maple top.

**Model CC-2M**



### Portable Clay Cabinet

A popular cabinet for clay storage plus additional storage space. Clay storage area includes plastic tub and anti-slam lid stay. Complete with four locking casters. Overall size is 37"W x 19-1/2"D x 22-1/2"H.  
**Model CC-1B**



**Multi-Purpose Planning Desk**

This versatile unit can be used as a desk, planning area or demonstration table. It is constructed of solid maple framing and maple panels with natural finish. Top is 1-1/4" x 72"W x 30"D plastic laminate. Table includes four general storage drawers and one file drawer fitted with master keyed cylinder locks. Below are four paper storage drawers. Overall table height is 36 3/4".

**Model D-631**

Same as D-631 but includes DM-2448 Demo Mirror.

**Model D-632**



**Instructor/Planning Desk**

The D-641 is a versatile unit that can be used as an instructor's desk or planning center. Pedestal includes three drawers and pull-out slide. Natural finish. Top surface is 1-1/4" thick plastic laminate. Overall size is 48"W x 30"D x 30"H. Shown in oak.

**Model D-641**



**Planning Table Series**

This table is ideal for general use as well as planning and designing. The table base is constructed of the finest hard maple with natural finish. Includes adjustable floor glides. Furnished with two large drawers 19-1/2"W x 19"D x 2-3/8"H. Plastic laminate top is 1-1/4" x 30" x 72". Overall height is 30".

**Model PL-2**

Similar to PL-2 except with 1-3/4" thick hard maple top.

**Model PL-2HM**

PL-2 planning table w/ DM-2472 demonstration mirror.

**Model DT-3072**

Larger version of the PL-2 w/ (4) drawers, top size is 72"W x 42"D.

**Model PL-3**

Similar to PL-3 except with 1-3/4" thick hard maple top.

**Model PL-3HM**



**Demonstration Mirrors**

Enhance student view of tabletop demonstrations. Mirror with safety backer is encased by an aluminum frame. Rotates 360 degrees and can be fixed at any angle. Sturdy supports are easily mounted to any table with four bolts.

22-5/8" x 28" mirror.  
For a 30" x 36" surface.  
**Model DM-2436**

22-5/8" x 52" mirror.  
For a 30" x 60" surface.  
**Model DM-2460**

22-5/8" x 40" mirror.  
For a 30" x 48" surface.  
**Model DM-2448**

22-5/8" x 64" mirror.  
For a 30" x 72" surface.  
**Model DM-2472**



**Hardwood Stools**

These attractive and sturdy stools are ideal for seating in the classroom or lab. They are available in maple or oak with natural finish and in three heights; 18", 24" and 30". The heavy duty seats are 1-1/4" thick and 13" in diameter. The legs are 1-1/2" in diameter and are tenoned into the bottom of the seat and secured with screws. The bottoms of the legs are rounded. Draw-tight stretchers are glued and pinned at stress points.

- |  |  |
|--|--|
| Maple stool, 18".<br><b>Model S-18-M</b> | Oak stool, 18".<br><b>Model S-18-O</b> |
| Maple stool, 24".<br><b>Model S-24-M</b> | Oak stool, 24".<br><b>Model S-24-O</b> |
| Maple stool, 30".<br><b>Model S-30-M</b> | Oak stool, 30".<br><b>Model S-30-O</b> |



**Student Bench**

The perfect addition to any common area or classroom requiring group seating. This attractive and sturdy bench is constructed of maple solids. Bench seat is attached to the legs with screws. The spreader supports the legs via bolt-reinforced mortise and tenon joints. Overall dimensions are 72"W x 16"D x 18"H.  
**Model SB-1672**



**Art Horse**

The art horse is designed for student comfort. The upright and grooved seat will accommodate boards up to 24" x 30". Made entirely of solid hard maple with natural finish. The seat is 12"W x 29"D x 17"H, and the drawing board rest is 12"W x 33"H.  
**Model B-1**



**Student Bench**

The B-2 bench provides maximum organization in the art room. It allows sturdy seating as well as additional storage. The durable unit is constructed of solid hard maple throughout with natural finish. Overall size is 17"W x 12"D x 17"H.  
**Model B-2**

## CAD Drafting Tables

These modern drafting tables can incorporate traditional drafting with CAD and graphic design. All of the tables feature solid hard maple construction with bolt-reinforced mortise and tenon joints. Available in a variety of sizes and configurations.



This drafting table includes with a six drawer storage unit, pullout keyboard tray, hanging steel CPU holder, monitor arm and wire management. An adjustable 30" x 30" x 3/4" Fibersin work surface is supported by a sturdy ratcheting mechanism. The right hand reference top measures 12" x 30". This unit stands 42"W x 30"D x 39"H at the front edge.

**Model CDWD-61**



Equipped with a pullout keyboard tray, CPU cabinet with tool drawer, monitor holder and wire management. An adjustable work surface, 30" x 30" is supported by a sturdy ratcheting mechanism. The reference top, 12" x 30", is supplied with a 2-1/2" grommet and cover. This unit is 42" W x 30"D x 39"H at the front edge.

**Model CDWD-65**



This table offers versatility and economy. Equipped with a pullout keyboard tray, hanging steel CPU holder, monitor arm and wire management. An adjustable 30" x 30" x 3/4" Fibersin work surface is supported by a sturdy ratcheting mechanism. The right hand reference top measures 12" x 30". This unit stands 42"W x 30"D x 39"H at the front edge.

**Model CDWD-66**



The ideal table for the student who needs computer accessibility as well as ample work space. A locking cabinet for the computer tower provides security against computer theft or damage. Designed so that the monitor can be positioned at the ideal eye-level. Overall size is 42"W x 40-1/2"D x 33"H.

**Model CAD-3042T-KB**

Same as above except with adjustable main top.

**Model CAD-3042T-ATKB**

**Hann Can!**<sup>SM</sup>

Drawing and Drafting tables represent the most customized items in our catalog! Options include everything from drawers, cubbies and shelves to dimensional variations and add on accessories. Hann can build a unique product that fits your needs.



Storage Options



Keyboard Tray



Monitor Arm



CPU Storage Options



Your Dimensions



### Drawing Table

The WD-1 table is constructed of hard maple framing to withstand demanding classroom use. Table has a full tilting Fibersin top (36"W x 24"D) with pencil ledge. Unit includes a ratchet type tilting mechanism. Center drawer is 19"W x 17"D x 2-3/4"H. Natural finish. Overall height is 37".

**Model WD-1**



**WD-2**



**WD-9**

### Split-Top Drawing Table

This single station drawing table includes an adjustable top (24"W x 24"D), ratchet type tilting mechanism, and full width pencil ledge. Top is 3/4" thick Fibersin. The reference area is 12"W x 24"D. Unit is complete with one storage drawer. Overall size is 36"W x 24"D x 30"H.

**Model WD-2**

Same as model WD-2, but 37" high.

**Model WD-3**

Same as model WD-2 less drawer.

**Model WD-9**

Same as model WD-3 less drawer.

**Model WD-10**



### Four Station Drawing Table w/ Under Top Storage

A versatile drawing table which features four drawing surfaces (30"W x 24"D) with center reference area. Drawing surfaces, complete with adjustable pencil ledges, can be folded down when not in use. Ratchet type tilting mechanisms allow a variety of working positions for each of the four stations. Lockable storage space beneath the adjustable drawing surfaces accommodate 18" x 24" drawing boards, T-squares, and tool storage. Mortise and tenon construction secures table rails to legs. Natural finish. Top surface is made of Fibersin. Overall size of the unit is 76"W x 48"D x 30"H.

**Model KD-4**



### Four Station Drawing Table

This four station drawing table has (4) 30"W x 24"D tilting Fibersin drawing surfaces and a fixed center top. The base is constructed of solid hard maple. The aprons are mortised into the legs providing strength and stability. The table is available with or without storage drawers in the front and rear aprons. Overall size of the unit is 76"W x 48"D x 30"H.

**Model WD-4876 (w/o drawers)**

**Model WD-4876-4D (w/ 4 drawers)**

A reduced size table for smaller classrooms. The tilting tops measure 24"W x 24"D. Overall size is 64"W x 48"D x 30"H.

**Model WD-4864 (w/o drawers)**

**Model WD-4864-4D (w/ 4 drawers)**

**Drawing Table Series with Optional Storage**

These sturdy Hann tables are ideal for drawing and drafting. Each table features a 3/4" thick Fibersin top that provides a rock hard, flat, smooth surface. A pencil ledge is standard. These tables are constructed of solid maple and hardwood panels and have a natural finish. You may choose additional options for any table series. Options include a six drawer tool storage unit and a drawing board storage cabinet.



Model WD-20

**WD-20 Series Fixed Top Drawing Table**

The top (36" x 24") is permanently fixed at a seven degree angle. Overall height is 39" at front.

Model WD-20, WD-21, WD-22, WD-23



Model WD-23



Model WD-50

**WD-50 Series Fixed Top Drawing Table**

The top is in two sections. The drawing top, 24" x 24", is permanently fixed at a seven degree tilt. The reference top, 12" x 24", is flat. Overall height is 39" at front.

Model WD-50, WD-51, WD-52, WD-53



Model WD-53



Model WD-30

**WD-30 Series Adjustable Top Drawing Table**

Top size is 42" x 30" and is adjusted via a ratchet-type tilting mechanism. Overall table height is 39".

Model WD-30, WD-31, WD-32, WD-33



Model WD-31



Model WD-60

**WD-60 Series Adjustable Top Drawing Table**

Top is split into two surfaces. The left side is a tilting top, 30"W x 30"D. The right side is a reference top, 12"W x 30"D. Overall size is 42" x 30" x 39" high.

Model WD-60, WD-61, WD-62, WD-63



Model WD-61

To designate model number choose series and options.  
**Example: Series WD-30 with drawing board storage cabinet = WD-32**

**OPTIONS**  
 0 - base model  
 1 - includes six drawer tool storage unit  
 2 - includes drawing board storage cabinet  
 3 - both six drawer unit and drawing board storage



### Dual Station Drawing Table w/ Storage Compartment

The model SA-20 art and drawing table includes two tilting adjustable tops, one drawer, and large storage compartment with adjustable shelf. Constructed of maple solids and panels throughout. Inverted A-frame legs provide sturdy foundation. Entire top area is 3/4" Fibersin, providing a rock hard, flat, smooth surface. Each tilting surface is 24" x 24" and includes ratchet type tilting mechanism along with pencil strip. Overall size is 60"W x 24"D x 36"H. Natural finish.

**Model SA-20**

The model SA-20B is similar to the model SA-20 table, except that the storage compartment is designed to accept six drawing boards size 18" x 24".

**Model SA-20B**



### Dual Station Drawing Table w/ Six Drawers

This Hann Manufacturing art and drawing table features two tilting adjustable tops, stationary center top, open bookshelf, and six drawers with master keyed locks. Constructed of maple solids and panels throughout. Inverted A-frame legs provide sturdy foundation. Entire top area is 3/4" thick Fibersin, providing a rock hard, flat, smooth surface. Each tilting top is 24" x 24" and includes ratchet type tilting mechanism along with pencil strips. Each drawer measures 11"W x 19-1/2"D x 2-1/4"H inside. Overall size is 60"W x 24"D x 36"H. Natural finish.

**Model SA-21**



### Technical Drafting Table

This unit is equipped with a 48"W x 37-1/2"D x 3/4" thick Fibersin top, and is adjustable with a ratchet-type tilting mechanism. Furnished with a pencil drawer and five storage drawers fitted with master keyed cylinder locks. Also included at the rear of the unit are two reference storage areas. Base is constructed of hard maple framing with hardwood paneling. Natural finish. Overall height is 37".

**Model WD-200**



### Drawing Table w/ Drawer Storage

A drawing table just right for the drafting lab or art room. A desk-high table with a large tilting Fibersin drawing surface (30" x 42") supported by dual adjustable ratchet type tilting mechanisms. The table provides six lockable drawers for secure storage. Sturdily built with maple solids and panels (shown in oak). Natural finish. Overall size of the unit is 42"W x 30"D x 30"H.

**Model WD-3042/6**



### Single Station Drawing Table w/ Six Drawers

This drawing table features six drawers large enough to hold boards, supplies, tools, and papers. Table is constructed of maple and has a natural finish. Entire top is 3/4" thick Fibersin. Tilt top is 33"W x 32"D and the reference top is 15"W x 32"D. Drawers are fitted with master keyed cylinder locks. Overall table size is 48"W x 32"D x 39-3/4"H.

**Model WD-8**



### Dual Station Drawing Table w/ Six Drawers

This two station tilt-top drawing table is constructed of maple solids and panels, with mortise and tenon construction for rugged durability. The Fibersin top provides a rock hard, smooth surface. Each tilting top measures 28" x 32"D and includes the ratchet type tilting mechanism. Stationary center top is 12" wide. Pencil strips are provided for each drawing surface. Knee space under each drawing area is 19-3/8" wide. Six drawers are supplied with master keyed cylinder locks. Overall size is 70-1/4"W x 32"D x 39-3/4"H.

**Model WD-80**



### Drawing Table Drawing Table w/ Eight Drawers

Similar to the WD-80 but includes eight drawers in the center pedestal, each 2"H.

**Model WD-82**



### Dual Station Drawing Table w/ Twelve Drawers

The WD-86 drawing table provides (10) drawers in the center pedestal and (1) apron drawer to the left and right for a total of (12) drawers. The table is constructed of maple solids and panels, with mortise and tenon joints for durability. Fibersin tops provide a rock hard, smooth drawing surface and are fixed at a seven degree angle. Each top measures 28"W x 32"D and slopes from 42-1/2" high at the front to 46-1/2" high at the back. Center reference area (21"W x 32"D x 40-3/4"H) is flat. Natural finish. Overall size is 77"W x 32"D x 46-1/2"H.

**Model WD-86**



**Drawing Supply Cabinet**

The DC-1 provides a complete facility for storing drafting materials for a class of 24 students. Included are a number of specially designed hooks and holders mounted in the cabinet. These will provide both adequate storage and visual check by the instructor. Drawing boards (18" x 24") are stored vertically in slots along the bottom row. There is ample storage space on the upper shelf for drawing supplies. Additionally, there is room for future expansion on the back of each door. Cabinet is constructed of solid maple framing with hardwood panels. Master keyed locks included. Natural finish. Overall size is 48"W x 22"D x 84"H. Cabinet does not include supplies.

**Model DC-1**

Same as DC-1, but for 36 students. 60"W x 22"D x 84"H.

**Model DC-2**



**Tote Tray Drawing Cabinet**

Solidly constructed of heavy maple framing with hardwood paneling throughout, this cabinet provides storage below for 24 drawing boards and at right center for 24 T-squares. Upper area includes 24 plastic tote trays (13-1/4"W x 19"D x 3-1/2"H). Natural finish. Includes master keyed lock. Overall size 48"W x 22"D x 84"H. Cabinet does not include drawing boards or T-squares.

**Model DC-5**

Same as DC-5, but for 36 students. 60"W x 24"D x 84"H.

**Model DC-5-36 (shown above)**



**Six Drawer Taboret**

Each drawer is 20"W x 26"D x 2"H. Top opening is 21"W x 28"D x 6-7/8"H. Fibersin top is 24-1/2"W x 32"D x 3/4" thick. Overall size of the unit is 24-1/2"W x 32"D x 32-3/4"H.

**Model T-60**

**Model T-60C (w/ casters)**



**Ten Drawer Taboret**

Each drawer is 20"W x 26"D x 2"H. Fibersin top measures 24-1/2"W x 32"D x 3/4" thick. Overall size of the unit is 24-1/2"W x 32"D x 39"H. (Shown in oak.)

**Model T-100**

**Model T-100C (w/ casters)**



**Drawing Board Cabinets**

This drawing board storage cabinet is available in two configurations. The first is outfitted with support cleats to provide storage for 25 boards 20" x 26". The other includes 27 hardboard shelves to hold drawing boards, artwork, and tools. The cabinets are constructed of solid hard maple framing and maple panels. Natural finish.

**Model DBS-1 (w/ cleats), 30"W x 22"D x 84"H**

**Model DBS-1S (w/ shelves), 31"W x 22"D x 84"H**

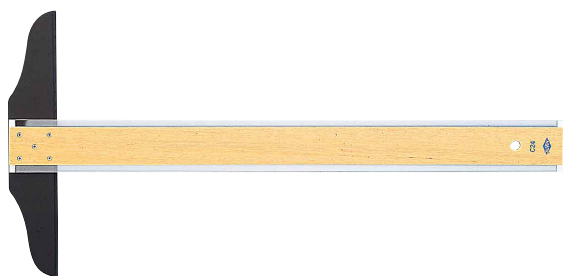

### Drawing & Drafting Tools

T-Squares feature select hardwood blades with see-through acrylic edges. The head is attached with five screws for lasting squareness. Available in several lengths.

Additional tools such as triangles and drawing boards are also available.



### Parallel Straightedge

This high quality straightedge features an integral brushed aluminum grip bar for easy positioning. The floating roller mechanism allows the straightedge to be moved with minimal effort and then locked in place. Available in several sizes.

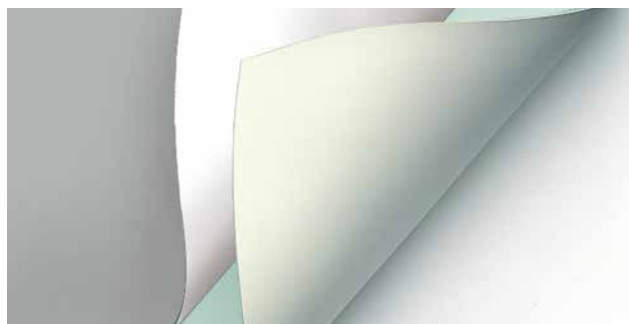

### Vycor Board Cover

This durable 5-ply cover provides a smooth, stain-resistant work surface for tables and drawing boards. Self-sealing surface quickly recovers from compass point, tack, and hard pencil impressions. The material will not deteriorate, discolor, or crack. Cuts easily with ordinary scissors. Available in multiple colors.



### Paint & Ink Storage Cabinet

This safety cabinet features powder coated steel construction and includes extra galvanized steel shelves for storage of 1-gallon cans and aerosols. Total storage capacity is 60 gallons. Doors are mounted on continuous hinges and utilize three point latches. Cabinet includes vents and leveling feet. Overall size 43"W x 18"D x 65"H.

**Model SAF-PI-47**, manual closing doors.

**Model SAF-PI-4510**, self-closing doors.



### Polyethylene Waste Cans

These poly cans offer fire safe temporary storage of solvent, waste rags, and other materials subject to spontaneous combustion. Poly material will not dent or rust and is resistant to most chemicals. Cans feature self-closing lid with foot lever.

**Model SAF-OW-933**, 6 gallon capacity

**Model SAF-OW-935**, 10 gallon capacity

**Model SAF-OW-937**, 14 gallon capacity



## Project Spaces

Whether you are furnishing an art room, career workshop or STEM lab, we have the furniture to support your projects. Create a dynamic and organized project space from our selection of sturdy tables, workstations, and storage solutions. Does your space have unique requirements? No problem - we offer to modify standard products or create entirely new ones to meet your needs.



PCTM Tables - page 19



SSC Cabinets - page 28



SPSC Carts - page 26



PCTM-3060M



PCTM-3060P

### Project Collaboration Tables

These mobile tables allow for use as smaller student tables or two of them can be joined together to make a larger project space when needed. Tables move on locking casters and can be joined and separated easily without the use of tools. Available with several types of tops. Overall height is 36".

#### Model Number Format: PCTM - (Top Size)(Top Type)

##### Top Size

30" x 60" - '3060'

30" x 72" - '3072'

##### Top Types

1-1/4" Thick Black HPL w/ 3mm PVC Edgeband - 'P'

1-3/4" Thick Hard Maple - 'M'

1" Thick Black Epoxy Resin - 'R'

#### Example Model Numbers:

PCTM-3060M - 1-3/4" x 30" x 60" hard maple top

PCTM-3072P - 1-1/4" x 30" x 60" black HPL top



PCTM-3060M - Joined



PCTM-3060P - Joined



STX-4848M



STX-4848P-36C

**X-Brace Tables**

This table series features lower 'x' cross bracing which provides a rock solid worksurface while allowing leg room on all four sides of the table. Available with multiple sizes and types of tops. Also available with locking casters.

**Model Number Format: STX - (Top Type) - (Height)(Options)**

**Top Types**

- 1-1/4" x 48" x 48" 'Maple Grain' Pattern HPL - '4848P'
- 1-1/4" x 60" x 60" 'Maple Grain' Pattern HPL - '6060P'
- 1-1/4" x 48" x 48" Black HPL - '4848PBK'
- 1-1/4" x 60" x 60" Black HPL - '6060PBK'
- 1-3/4" x 48" x 48" Hard Maple - '4848M'
- 1-3/4" x 60" x 60" Hard Maple - '6060M'

**Overall Height (Approx.)**

- 30" - Standard (no suffix)
- 36" - '36'

**Options**

- Locking Casters - 'C'

**Example Model Numbers:**

- STX-4848M-36C** - 1-3/4" x 48" x 48" hard maple top, 36" overall height, locking casters
- STX-4848PBK-36** - 1-1/4" x 48" x 48" black HPL top, 36" overall height, no casters
- STX-6060P** - 1-1/4" x 60" x 60" 'maple grain' patterned HPL top, 30" overall height, no casters



**Project Assembly Bench**

Solid hard maple open leg based workbench. All models include four legs, lower shelf, and rear stringer. Maple top available in two thicknesses. Overall height is 29-3/4" plus top thickness.

Top Size	1-3/4" Top	2-1/4" Top
24" x 48"	W-2310	W-4310
24" x 60"	W-2311	W-4311
24" x 72"	W-2312	W-4312
24" x 96"	W-2309	W-4309
30" x 48"	W-2313	W-4313
30" x 60"	W-2314	W-4314
30" x 72"	W-2315	W-4315
30" x 96"	W-2316	W-4316



STW-5464M-36C



STW-5464P

### Project Worktables

This table series features mortise and tenon joints throughout and includes a lower storage shelf. Several choices of top. For 42" x 60" tops, overhang is roughly 7" on all sides. For 54" x 64" tops, overhang is roughly 10" on all sides. Available with locking casters.

**Model Number Format: STW - (Top Type) - (Height)(Options)**

#### Top Types

1-1/4" x 42" x 60" 'Maple Grain' Pattern HPL - '4260P'  
 1-1/4" x 54" x 64" 'Maple Grain' Pattern HPL - '5464P'  
 1-1/4" x 42" x 60" Black HPL - '4260PBK'  
 1-1/4" x 54" x 64" Black HPL - '5464PBK'  
 1-3/4" x 42" x 60" Hard Maple - '4260M'  
 2-1/4" x 54" x 64" Hard Maple - '5464M'

#### Overall Height (Approx.)

30" - Standard (no suffix)  
 36" - '36'

#### Options

Locking Casters - 'C'

#### Example Model Numbers:

**STW-4260M-36C** - 1-3/4" x 42" x 60" hard maple top, 36" overall height, locking casters

**STW-5464P** - 1-1/4" x 54" x 64" 'maple grain' patterned HPL top, 30" overall height, no casters



WL4-0V



WL5-0V

### Project Workbench

A sturdy foundation for any project activity. Constructed of solid hard maple including the lower slat shelf. Spreaders are secured to the legs via bolt-reinforced mortise and tenon joints. The hard maple top is 2-1/4" thick. Available in both 4-student and 2-student sizes. Top overhangs the base by roughly 10" on all sides of the 4-student version. Overall height is 32". Also available with woodworking vises.

Four student version, top measures 54" x 64", no vises.

**Model WL4-0V**

Two student version, top measures 28" x 64", no vises.

**Model WL5-0V**



SFT-FW-3060M-36C

### Tubular Steel Worktables

This table series is constructed from 12 ga, 2” square tubular steel. Available either as fully welded or knock-down assembly. Base is finished in black. Several top options to choose from. Furnished with adjustable glides as standard, locking casters are an available option.

**Model Number Format:** SFT - (Welded/KD) - (TopType) - (Height)(Options)

**Top Types**

- 1-1/4” x 30” x 60” Black HPL - ‘3060PBK’
- 1-1/4” x 30” x 72” Black HPL - ‘3072PBK’
- 1-3/4” x 30” x 60” Hard Maple - ‘3060M’
- 1-3/4” x 30” x 72” Hard Maple - ‘3072M’
- 1” x 30” x 60” Black Phenolic Resin - ‘3060T’
- 1” x 30” x 72” Black Phenolic Resin - ‘3072T’

**Construction**

- Fully Welded - ‘FW’
- Knock-Down - ‘KD’

**Overall Height (Approx.)**

- 30” - Standard (no suffix)
- 36” - ‘36’

**Options**

- Locking Casters - ‘C’

**Example Model Numbers:**

- SFT-FW-3072PBK-36C - Fully welded frame, 1-1/4” x 30” x 72” black HPL top, 36” overall height, locking casters
- SFT-KD-3060M - Knock-down frame construction, 1-3/4” x 30” x 60” hard maple top, 30” overall height, no casters



MAH-2314-C

### Adjustable Height Steel Leg Workbenches

This sturdy workbench is constructed from steel channel. Telescoping legs can be adjusted for a overall height of 26” to 36”. The base includes a rear brace and lower shelf. Finished in gray. The 1-3/4” thick hard maple top is available in multiple sizes. Furnished with adjustable glides as standard, locking casters are an available option.

**Model Number Format:** MAH - (Top Size) - (Options)

**Top Sizes**

- 1-3/4” x 30” x 60” Hard Maple - ‘2314’
- 1-3/4” x 30” x 72” Hard Maple - ‘2315’

**Options**

- Locking Casters - ‘C’

**Example Model Numbers:**

- MAH-2314-C - 1-3/4” x 30” x 60” hard maple top, locking casters
- MAH-2315 - 1-3/4” x 30” x 72” hard maple top, adjustable glides

### Project Bench Series

Hann's four station benches are ideal for use in the school shop, STEM project area, or art department. Maple top is 54" x 64" x 2-1/4" thick. Bases are made of heavy maple framing and hardwood paneling with natural finish. Overall height is 33-1/4". To add versatility, optional woodworking vises can be supplied. Locking casters are an option for models without vises.

The LCB-30 base consists of two 6-drawer cabinets (35"W x 22"D x 31"H) placed back-to-back. The LCB-31 base consists of two double door cabinets. The LCB-32 series cabinets consist of two drawers above double doors. The LCB-37 series cabinets consist of three drawers and one swinging door. The LCBL-4 base consists of two cabinets with 6 locker compartments each.



Shown with optional casters.



**LCB-30-0V** - (0) Vises  
**LCB-30-0V-C** - (0) Vises, Casters  
**LCB-30-4V** - (4) Vises



**LCB-31-0V** - (0) Vises  
**LCB-31-0V-C** - (0) Vises, Casters  
**LCB-31-4V** - (4) Vises



**LCB-37-0V** - (0) Vises  
**LCB-37-0V-C** - (0) Vises, Casters  
**LCB-37-4V** - (4) Vises



**LCB-31-0V** - (0) Vises  
**LCB-31-0V-C** - (0) Vises, Casters  
**LCB-31-4V** - (4) Vises



**LCB-37-0V** - (0) Vises  
**LCB-37-0V-C** - (0) Vises, Casters  
**LCB-37-4V** - (4) Vises

### Wall Benches

Hann's complete series of wall benches are available in a variety of base configurations and top styles to suit any requirement. Wall benches are sturdily constructed of hard maple framing and panels with natural finish. All drawers feature dovetail construction. Optional cylinder locks can be furnished. 'WTB' base cabinets have six drawers. 'WBB' base cabinets have three drawers and one door and the 'WWB' bases have two doors.



**WTB-10L**



**WBB-6L**



**WWB-6L**

**Model Number Format: (Base Cabinet Style) - (Top Size)(TopType) - (Height)**

**Base Cabinet Style**

Drawers Only - 'WTB'  
 Drawer/Door - 'WBB'  
 Double-Door - 'WWB'

**Top Sizes**

24" x 72" (Includes 2 Base Cabinets) - '6'  
 24" x 96" (Includes 2 Base Cabinets) - '8'  
 24" x 120" (Includes 3 Base Cabinets) - '10'  
 24" x 144" (Includes 4 Base Cabinets) - '12'

**Top Types**

1-3/4" Thick Hard Maple - 'L'  
 1-1/4" Thick 'Maple Grain' HPL - 'P'  
 1-1/4" Thick Black HPL - 'PBK'

**Overall Height (Approx.)**

30" - Standard (no suffix)  
 36" - '36'

**Example Model Numbers:**

**WTB-10L** - (3) Base cabinets w/ (6) drawers each, 1-3/4" x 24" x 120" hard maple top, ~30" overall height  
**WWB-6P** - (2) Base cabinets w/ double-doors, 1-1/4" x 24" x 72" 'maple grain' HPL top, ~30" overall height  
**WBB-6PBK-36** - (2) Base cabinets each w/ (3) drawers and single door, 1-1/4" x 24" x 72" black HPL top, ~36" overall height

**Project Workstations**

These workstations serve as excellent project centers providing both a large, sturdy worksurface as well as a storage for both tools and large format materials. All workstations are available with either a 2-1/4" x 54" x 64" hard maple top or a 1-1/4" x 54" x 64" 'maple grain' patterned HPL top. The base of the workstation consists of two cabinets placed back-to-back. Base cabinets are built using heavy-duty solid hard maple face frame construction. The top overhangs the base cabinets by roughly 9" on all sides allowing for seating around the entire perimeter of the workstation. Overall height is 33-1/4".



AWS-3331

This workstation features a 6-drawer cabinet for paper and tool storage on one side and a double-door cabinet with an adjustable shelf for flexible storage of larger project items on the other side. Each drawer measures 31"W x 23"D x 1-3/4"H (I.D.).

- Model AWS-3331**      Hard maple top
- Model AWS-3331-C**    Hard maple top, casters
- Model AWS-3331-P**      HPL top
- Model AWS-3331-P-C**    HPL top, casters



AWS-3332U-P

One side of this workstation features a 6-drawer cabinet for paper and tool storage. Each drawer measures 31"W x 23"D x 1-3/4"H (I.D.). The cabinet on the opposite side of the unit includes a double-door cupboard area in the upper section and two storage drawers below.

- Model AWS-3332U**      Hard maple top
- Model AWS-3332U-C**    Hard maple top, casters
- Model AWS-3332U-P**      HPL top
- Model AWS-3332U-P-C**    HPL top, casters

**Steel Base Project Workstations**

These workstations are available in both four-station and two-station sizes. The four-station models include two gray base cabinets placed back-to-back and a 2-1/4" x 54" x 64" hard maple top. The two-station models include a single base cabinet and a 2-1/4" x 28" x 64" hard maple top. The base units are available in a variety of storage configurations to suit your specific requirements. Overall workstation height is 33-1/4".

For all configurations and options, please see pages 59 - 62.



L4-0V



L5-2V

## Robotics Workstation

This series of workbenches is the perfect centerpiece for any robotics program. The double-sided base provides ample storage while the top acts as both an assembly area and proving ground. The base cabinets can be configured to include shelf storage, drawers, or a combination of both. The base is constructed of solid hard maple and hard maple plywood and features heavy-duty face frame construction. The center of the top is Fibersin which provides a smooth, hard surface that is easy to clean. The perimeter of the top is 3/4" thick solid hard maple which extends 1-1/2" above the Fibersin surface. The result is a sturdy work surface that keeps small parts from falling onto the ground and provides a functional perimeter for robot trials. The top overhangs the base by roughly 9" on all sides. The overall size of the workstation is 49"W x 61"D x 32"H.

As with nearly all Hann products, we can modify the size or configuration of the workstation to best meet your needs.



**SWRS-3131**



**SWRS-3232U**

## Project Work Center

This work center provides plenty of storage and work space for any project. The double-sided cabinet is composed of solid hard maple and hard maple plywood and features heavy-duty face frame construction. It includes double-door storage at the front and rear as standard. The 1-1/4" thick 'maple grain' pattern HPL top overhangs the base on all sides allowing for easy access to the entire work surface. The overall size of the workstation is 54"W x 64"D x 36"H. Available with or without locking casters. Also available with other top types and base cabinet styles.

Fixed base.

**Model SWS-3131P**

Version with locking casters.

**Model SWS-3131P-C**



**SWS-3131P**



**SWS-3131P-C**

### Mobile Project Support Cart

This mobile cabinet series includes different storage configurations and is available with or without doors. The cabinet is constructed of a thick solid hard maple face frame and hard maple panels. The 1-1/4" x 23" x 36" thick HPL top has 3mm PVC edgebanding and is available in either black or a 'maple grain' pattern. The cabinet moves on lockable 4" casters. The overall cabinet size is 36"W x 23"D x 30"H.

Includes (2) storage drawers and lower section w/ (2) adjustable shelves and (6) tote trays. The inside dimensions of the drawers are 12-3/4"W x 19"D x 3-1/4"H.

**Model SPSC-2D2S6T** (w/o doors)

**Model SPSC-2D2S6T-WD** (w/ doors)

Includes (2) storage drawers and lower section includes (1) adjustable shelf. The inside dimensions of the drawers are 12-3/4"W x 19"D x 3-1/4"H.

**Model SPSC-2D1S** (w/o doors)

**Model SPSC-2D1S-WD** (w/ doors)



SPSC-2D2S6T



SPSC-2D1S



SPSC w/ Doors

### Mobile Tote Tray Cabinet

This tote tray cabinet is ideal for storing and organizing materials and tools by student, project, or both. The thick solid hard maple face frames at the front and rear feature mortise and tenon joinery. The frames are machined to receive the cabinet end panels and bottom resulting in a rigid interlocking shell. All hinges and casters are mounted to solid wood. The cabinet includes (24) tote trays with inside dimensions of approximately 12-1/2"W x 18"L x 3-1/2"D. The trays are stored on sturdy steel racks. The locking 4" casters allow for the cabinet to be rolled out to a project work center when necessary and moved out of the way when not in use. Available with or without locking doors. Overall size is 48"W x 22"D x 46"H.



SC-4824WD



SC-4824

## Mobile Project Storage Series

These mobile storage cabinets are available in a variety of configurations to suit any storage need. Large enough to provide generous storage capacity yet small enough to allow for easy movement. They are ruggedly constructed of hard maple solids and panels and feature front and rear frames. The cabinets include locking doors and move easily on 4" casters. All hinges and casters are secured to solid wood. Overall size is 48"W x 22"D x 66"H.



### General Shelving Storage

This version includes three adjustable shelves. Shelves are supported by steel shelf uprights and shelf clips.

**Model SC-200M**



### Tote Tray Storage

This mobile storage cabinet provides tote tray storage for the whole class as well as general shelf storage. It includes (24) tote trays with approximate inside dimensions of 12-1/2"W x 18"L x 3-1/2"D. Tote trays are supported on sturdy steel racks.

**Model SC-230TTM**



### Project Tool Storage

This unit includes an inner pegboard rear panel, two full width shelves, and six tote trays. Great for tool and parts storage.

**Model TS-200M**



### Tote Tray/Shelf Storage

A combination of tote tray storage with plentiful shelf storage. It includes (2) partial-width adjustable shelves, (1) full-length fixed shelf, seven hardboard shelves, and (8) tote trays.

**Model SC-231TTM**

### Large Capacity Project Storage Cabinet

An excellent option for storing large containers of project materials and tools. The extra cabinet depth allows storage of tubs and other containers up to 24" deep. Built from solid hard maple and hard maple panels, this cabinet series features our standard heavy-duty face frame construction. The sturdy shelves are braced on (3) sides by steel shelf supports and the front edge is reinforced by a solid hard maple nosing. The overall cabinet size is 48"W x 26"D x 84"H.

Includes a center fixed shelf and (3) adjustable shelves in the upper section. The lower section is a garage intended to house a project support cart or any mobile cabinet smaller than 40"W x 23"D x 31"H.

**Model SSCG-21-26D-3S** (shown below w/ SPSC project support cart - sold separately)

Full height shelving storage. Includes a center fixed shelf and (4) adjustable shelves.

**Model SSC-21-26D-4S**



SSCG-21-26D-3S



SSC-21-26D-4S

### Combo Storage Cabinet

This cabinet will meet almost any storage requirement. It includes (4) adjustable shelves in the upper storage area and (4) drawers below. The drawer inside dimensions are approximately 19-1/2"W x 19"L x 4-1/2"D. Overall size is 48"W x 22"D x 84"H.

**Model TS-2**

### General Shelving Storage

Constructed of hard maple framing and panels with a heavy-duty face frame. Fixed center shelf and (4) adjustable shelves provide a generous amount of storage to help organize your project supplies. Overall size is 48"W x 22"D x 84"H. Also available in other sizes.

**Model SC-21**



### Tote Tray Storage Cabinets

These cabinets provide organization of project supplies by student, project, or both. Rugged face-frame cabinet construction of hard maple solids and panels. Tote trays are constructed of high-impact polystyrene and include label holders. Tray inside dimensions are approximately 12-1/2"W x 18"L x 3-1/2"D. Tote trays are stored on steel racks. Overall cabinet size is 48"W x 22"D x 84"H.

Includes (48) tote trays.

#### Model TT-3

Includes (24) tote trays in the lower section and (3) adjustable shelves in the upper section.

#### Model TT-4



TT-3



TT-4

### Tote Tray Garage Cabinet

This cabinet includes (8) adjustable shelves and (27) tote trays in the upper section. The bottom section of the cabinet acts as a garage for mobile tote tray carts or any other type of mobile cart. The garage space is 45"W x 19"D x 35"H. Overall size is 48"W x 22"D x 84"H.

#### Model TTG-482284-27T

(shown below w/ MSTT cart - sold separately)



### Mobile Tote Tray Cart

Holds (12) wide tote trays with approximate inside dimensions of 16"W x 16"D x 3"H. Sturdy cart features fully welded front and rear steel frames. Tote tray runners allow trays to be partially opened and accessed without falling out. Cart's lipped top is perfect for transporting additional tote trays and supplies. Overall size is 41"W x 17"D x 29"H.

#### Model MSTT-212W





**Student Tables**

These tables provide work space for two or more students and are available with plain aprons, bookwells or drawers. Legs are 2-1/4" square and include black vinyl boots and adjustable glides. Standard height is 30", but tables are available in other heights. Natural finish is standard. See page 49 for additional construction details. Descriptions of the various types of tops available are on page 27. Tops are attached at the factory prior to shipment. See below for model numbers.



“-MT” Legs mortised to slide onto apron tenons



“-SS” Lower spreaders & stretchers

To designate model #: ST (style) (species) - (size) (top) - (options)

**Example:** STPM-2454R-36 ST (Plain Aprons) (Maple) - (24" x 54") (Epoxy Resin) - (36" High)

step 1: select a style:



STB - Bookwells



STD - Drawers



STP - Plain Apron



STS - Scalloped

step 2: select a species of wood:

M - hard maple  
O - red oak

step 3: select a size:

24" x 48"  
24" x 54"

24" x 60"  
24" x 72"

24" x 96"  
30" x 60"

42" x 60"  
42" x 72"

step 4: select a top:



C - Chemsurf



M - Maple

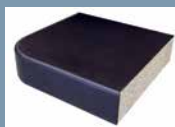

P - Plastic Lam.



R - Epoxy

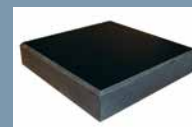

T - Phenolic

step 5: available options:

Height (30" is std.)

-34 (34" High)  
-36 (36" High)

Spreaders

-SS

Mortise & Tenon

-MT

Self-Level Glides

-SLG

### Wall Cabinets

These wall cabinets compliment the Hann Manufacturing line of solid hardwood bases. The wall cabinets are built of hard maple or oak framing and veneercore plywood. The face frames are assembled using mortise and tenon construction. Each cabinet is fitted with two adjustable shelves and has a natural finish. Master keyed cylinder locks furnished upon request. All units are 30" high.

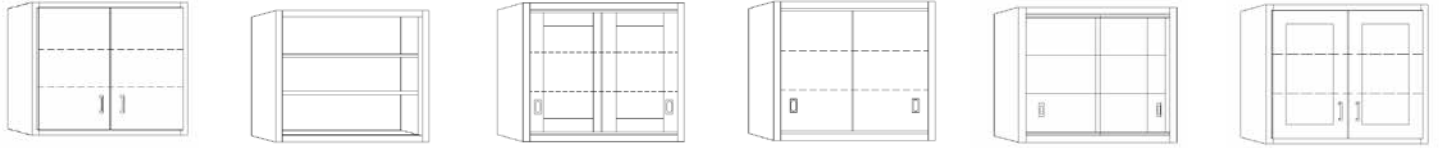

<b>Model</b> <b>W x D</b>	<b>Model</b> <b>W x D</b>	<b>Model</b> <b>W x D</b>	<b>Model</b> <b>W x D</b>	<b>Model</b> <b>W x D</b>	<b>Model</b> <b>W x D</b>
<b>WH-21</b> 24"x12"	<b>WH-57</b> 24"x12"	<b>WH-235GG</b> 35" x12"	<b>WH-23</b> 24"x12"	<b>WH-25</b> 24"x12"	<b>WH-125GG</b> 24" x12"
<b>WH-22</b> 24"x16"	<b>WH-58</b> 24"x16"	<b>WH-236GG</b> 35" x16"	<b>WH-24</b> 24" x16"	<b>WH-26</b> 24" x16"	<b>WH-126GG</b> 24"x16"
<b>WH-31</b> 35"x12"	<b>WH-67</b> 35"x12"	<b>WH-245GG</b> 47" x12"	<b>WH-33</b> 35"x12"	<b>WH-35</b> 35"x12"	<b>WH-135GG</b> 35" x12"
<b>WH-32</b> 35"x16"	<b>WH-68</b> 35"x16"	<b>WH-246GG</b> 47" x16"	<b>WH-34</b> 35"x16"	<b>WH-36</b> 35"x16"	<b>WH-136GG</b> 35" x16"
<b>WH-41</b> 47"x12"	<b>WH-77</b> 47"x12"		<b>WH-43</b> 47"x12"	<b>WH-45</b> 47"x12"	<b>WH-145GG</b> 47" x12"
<b>WH-42</b> 47"x16"	<b>WH-78</b> 47"x16"		<b>WH-44</b> 47"x16"	<b>WH-46</b> 47"x16"	<b>WH-146GG</b> 47" x16"

### Base Cabinets

Cabinet construction includes a solid hard maple or red oak face frame with mortised and tenoned glue joints. A recessed toe space is provided. All drawers feature dovetail construction. Pulls and hinges are heavy duty. All units receive multiple coats of natural finish. Cabinets are furnished less locks, but cylinder locks can be provided for any or all openings as an option. Where cabinet backs are exposed to view, finished backs can be specified. Note: All cabinets are priced without tops. A variety of top materials and sizes are available. Standard cabinet heights are 29" and 35" and standard depth is 22".

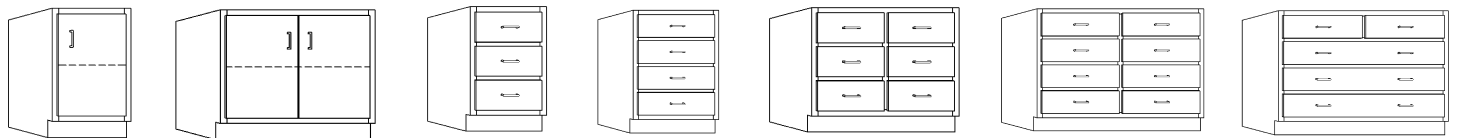

<b>Model</b> <b>H x W</b>	<b>Model</b> <b>H x W</b>	<b>Model</b> <b>H x W</b>	<b>Model</b> <b>H x W</b>	<b>Model</b> <b>H x W</b>	<b>Model</b> <b>H x W</b>	<b>Model</b> <b>H x W</b>
<b>BC-11A</b> 29" x 13 5/8"	<b>BC-31</b> 29" x 35"	<b>BC-10A</b> 29" x 13 5/8"	<b>BC-120</b> 35" x 24"	<b>BC-30</b> 29" x 35"	<b>BC-130</b> 35" x 35"	<b>BC-146</b> 35" x 47"
<b>BC-11</b> 29" x 18"	<b>BC-41</b> 29" x 47"	<b>BC-10</b> 29" x 18"		<b>BC-40</b> 29" x 47"	<b>BC-140</b> 35" x 47"	
<b>BC-21</b> 29" x 24"	<b>BC-131</b> 35" x 35"	<b>BC-20</b> 29" x 24"				
<b>BC-121</b> 35" x 24"	<b>BC-141</b> 35" x 47"					

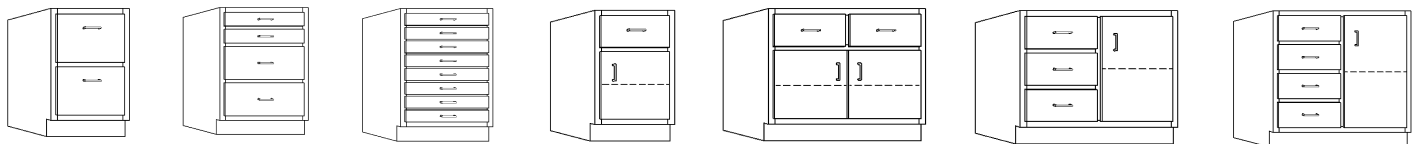

<b>Model</b> <b>H x W</b>	<b>Model</b> <b>H x W</b>	<b>Model</b> <b>H x W</b>	<b>Model</b> <b>H x W</b>	<b>Model</b> <b>H x W</b>	<b>Model</b> <b>H x W</b>	<b>Model</b> <b>H x W</b>
<b>BC-16</b> 29" x 18"	<b>BC-18</b> 29" x 18"	<b>BC-123</b> 35" x 24"	<b>BC-12</b> 29" x 18"	<b>BC-32</b> 29" x 35"	<b>BC-37</b> 29" x 35"	<b>BC-137</b> 35" x 35"
	<b>BC-28</b> 29" x 24"		<b>BC-22</b> 29" x 24"	<b>BC-42</b> 29" x 47"	<b>BC-47</b> 29" x 47"	
			<b>BC-122</b> 35" x 24"	<b>BC-132</b> 35" x 35"		
				<b>BC-142</b> 35" x 47"		

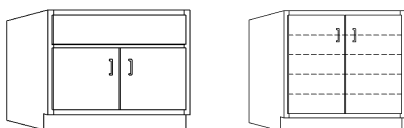

<b>Model</b> <b>H x W</b>	<b>Model</b> <b>H x W</b>
<b>BC-32S</b> 29" x 36"	<b>BC-135</b> 35" x 35"
<b>BC-132S</b> 35" x 36"	

### Laboratory Display Cabinets

These solidly constructed cabinets offer ample, secure storage and display for labs and classrooms. Base cabinets measure 22"D x 36"H" and are available in several styles. Countertop is 1" thick black epoxy resin. Upper display cabinets include sliding framed glass doors and three adjustable shelves. The upper cabinet measures 16"D x 48"H.



#### Cabinet w/ Four Drawers and Cupboard

Base supplied with four storage drawers; cupboard with adjustable shelf.

36"W x 24"D x 84"H.  
**Model SC-137G**

48"W x 24"D x 84"H.  
**Model SC-147G**



#### Cabinet w/ Two Drawers and Cupboard

Base supplied with two storage drawers; cupboard with two doors.

36"W x 24"D x 84"H.  
**Model SC-132G**

48"W x 24"D x 84"H.  
**Model SC-142G**



#### Cabinet w/ Eight Drawers

Base is supplied with eight drawers.

36"W x 24"D x 84"H.  
**Model SC-130G**

48"W x 24"D x 84"H.  
**Model SC-140G**



#### Cabinet w/ Lower Cupboard

Base supplied with double doors and adjustable shelf.

36"W x 24"D x 84"H.  
**Model SC-131G**

48"W x 24"D x 84"H.  
**Model SC-141G**  
(Shown above in maple)



#### Skeleton Storage Cabinet

This cabinet provides secure storage and display space for the human skeleton. Includes a pull-out carrier that allows the skeleton to be rotated for classroom study. Locking framed glass door. Skeleton not included.

Overall size is 27"W x 16"D x 84"H  
**Model SC-1627GSS**



#### Microscope Storage Cabinets

These cabinets provide secure, organized storage of microscopes. They include a fixed center shelf and four adjustable shelves. Locking framed glass doors. Spaces for microscopes measure 7"W x 14"D x 14-1/2"H.

Storage for up to 15 microscopes.  
Overall size is 27"W x 16"D x 84"H  
**Model SC-1627GMS**

Storage for up to 30 microscopes.  
Overall size is 48"W x 16"D x 84"H.  
**Model SC-1648GMS**



#### Mobile Microscope Cabinet

Mobile cabinet designed to transport microscopes conveniently and safely. This cabinet will accommodate twenty-four microscopes on two shelves. Microscope storage area measures 7"W x 9"D x 16-1/2"H. Access is from both sides through lockable sliding doors. Black HPL top measures 48" x 24". Moves on heavy duty casters. Overall height is 41".  
**Model MSC-2449**



**Mobile Demo Bench**

This bench is a completely self-contained portable unit. Supplied with lockable sliding doors; four large tote trays for supplies; drop-leaf top extension; stainless steel sink; duplex receptacle with extension cord; aluminum rod with crossbar; four locking casters.

Overall size is 64"W x 24"D x 35"H

Top: 50"W x 24"D x 1-1/4" thick

Drop leaf: 14"W x 24"D

Sink: 10"W x 10"D x 12"H

**Model BC-2464C-BD**, with Chemsurf top.



**Mobile Demo Bench with Mirror**

This bench is ideal when space for classroom demonstrations are at a minimum. Supplied with laminated plastic top; a moveable overhead mirror; two end shelves; lockable storage compartment; four lockable drawers; two adjustable storage shelves; four locking casters. Overall size including end shelves is 79-3/4"W x 24"D x 36"H

Drop leaves: 16"W x 20"D

Mirror: 28"W x 22-5/8"H

**Model BC-148MD**



**Portable Demonstration Cart**

This multi-function cart works as a demonstration station that can be moved easily from the storage room to the laboratory. Available with several types of tops. Includes lower shelf, locking casters. Overall size is 36"W x 24"D x 30"H.

**Model SAB-2436C**, with Chemsurf top.

**Model SAB-2436M**, with maple top.

**Model SAB-2436P**, with HPL top.

**Model SAB-2436R**, with epoxy resin top.



**Mobile Supply Cabinet**

This mobile unit offers generous storage behind lockable sliding doors. Includes (4) pullout drawers on the right side and a storage area with an adjustable shelf on the left side. Drawers measure 4-1/2"H x 16-1/2"W x 16"D. The top measures 24" x 48". Overall size is 48"W x 24"D x 36"H. Shown in red oak.

**Model MBC-2448C**, with Chemsurf Top.

**Model MBC-2448P**, with HPL Top.

**Model MBC-2448R**, with Epoxy Resin Top.



**Mobile Demonstration Station**

This portable cabinet is equipped to support a wide range of demonstrations. The 1-1/4" thick Chemsurf top measures 30" x 54". Includes a stainless steel sink w/ pump faucet, freshwater and wastewater containers, a GFCI outlet with extension cord. Base includes (4) lockable drawers. Overall size is 54"W x 30"D x 36"H. Shown in red oak.

**Model MBC-3054C**



**Clean-Up Sink**

This sink unit features a molded polyolefin top with drain grooves on either side of the sink and raised perimeter edges. The integral sink measures 24" x 18" x 12"D. Includes a laboratory grade mixing faucet. The cabinet has storage cupboards on the left and right. Overall size is 56"W x 28"D x 36"H. Shown in red oak.

**Model BC-152S-PO**



**Instructor's Demonstration Bench**

A compact yet complete demo station. Consists of one sink cupboard and one four-drawer cabinet w/ pull-out tablet shelf. Door and drawers have master keyed cylinder locks. Includes one cold water faucet, one single turret mounted gas cock, one GFCI receptacle, one epoxy resin sink with outlet, and an apparatus rod assembly. Shown in oak.

Overall size: 60"W x 30"D x 36"H

Base cabinets: 18"W x 28"D x 35"H

Sink: 10"W x 14"D x 6"H

**Model SD-305R**, with epoxy resin top.

**Model PT-305WOS**, same as SD-305 with Chemsurf top, less all plumbing fixtures.



**Instructor's Demonstration Bench**

A popular instructor workstation that provides ample facilities for classroom demonstrations. Furnished with one double door sink cupboard and one five-drawer cabinet. All doors and drawers have master-keyed locks. Includes mixing faucet, one double turret mounted gas cock, one GFCI receptacle, one epoxy resin sink with outlet, and an apparatus rod assembly. Overall size: 96"W x 30"D x 36"H

Base cabinets: 35"W x 28"D x 35"H

Sink: 15"W x 18"D x 11"H

**Model SD-308R**, with epoxy resin top.

**Model PT-308WOS**, same as SD-308 with Chemsurf top, less all plumbing fixtures.



**Instructor's Side Desk**

Designed as an attachment to the SD-305 and SD-308 demonstration tables. The desk may be installed on either end of the demo unit. Includes a three drawer base cabinet, a full box apron with drawer, modesty panel and top. All drawers include master keyed locks.

Options include: bookshelf at rear of the desk, apron w/ pullout keyboard tray.

Overall size is 48"W x 30"D x 30"H.

**Model ISD-48R**, w/ epoxy resin top.

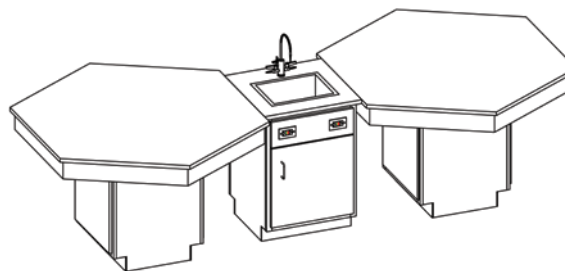
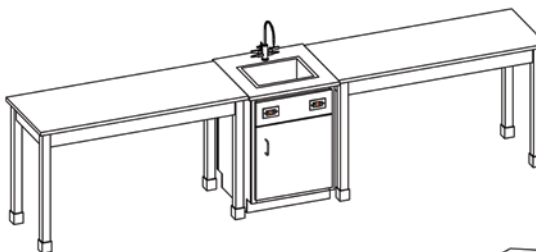
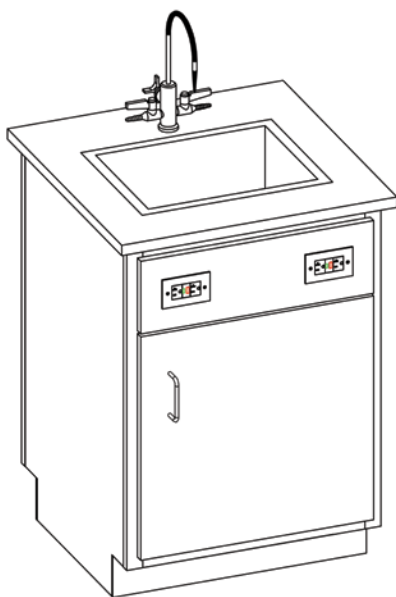

Combine the service island with student tables or plain top workstations.

**Laboratory Service Island**

Maximize flexibility and usable table top work space by utilizing this island cabinet to house all of the required services. The island has an epoxy resin top and 16" x 12" x 8"D epoxy resin sink. It is equipped with a cold water/gas combo faucet and two duplex GFCI receptacles. Overall size of the unit is 26"W x 26"D x 36"H.

**Model LSI-2626R**

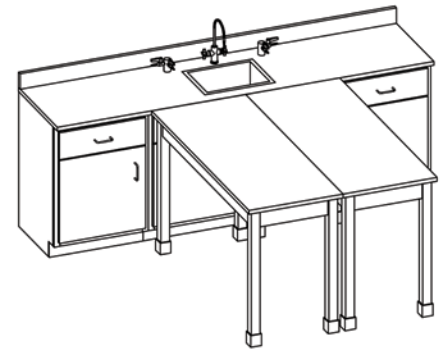
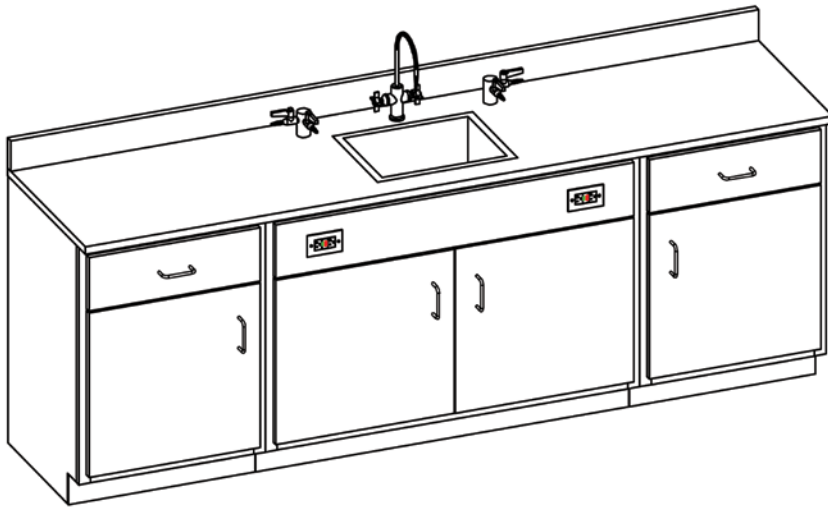

Two 24" wide student tables can be used as a peninsula.

### Wall Service Bench

This wall assembly provides both storage and services. The center sink base cabinet includes two duplex GFCI receptacles. The two outer base cabinets measure 24"W and are available in a number of configurations. The countertop and backsplash are 1" thick epoxy resin. The epoxy resin sink measures 16" x 12" x 8"D. Fixtures include a mixing faucet and two double gas fixtures. Overall size is 96"W x 24"D x 36"H.

**Model Naming Convention:** WSB - (Left Base Cabinet Style)(Right Base Cabinet Style) R

**Model Shown Above:** WSB-2222R

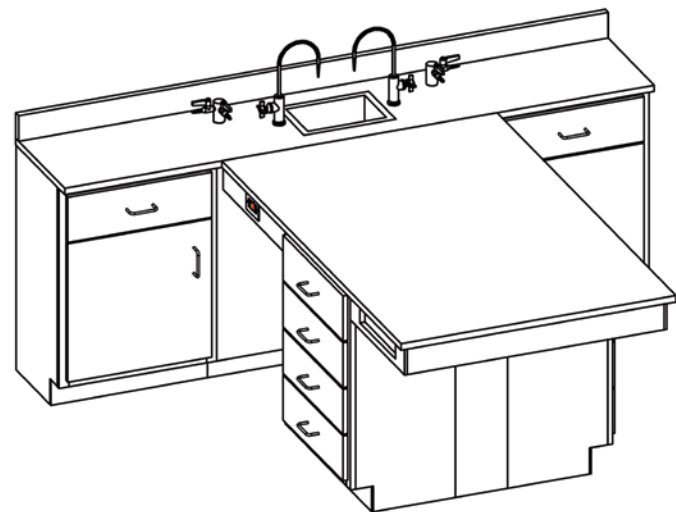
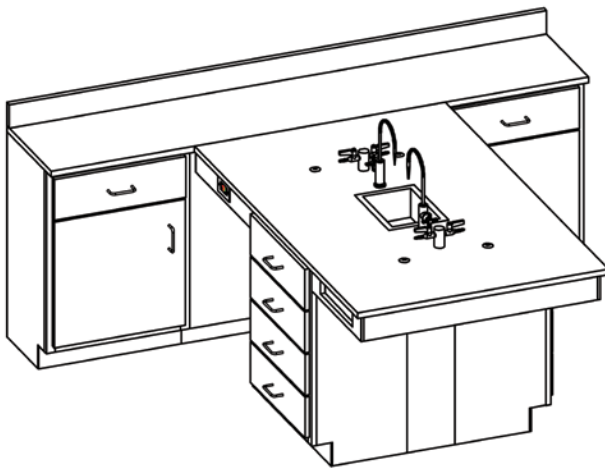

### Perimeter Workstation

The perimeter workstation is a "T" shaped, double-faced, four student peninsula lab table with additional work space along the walls. All frames assembled with mortise and tenon construction. The top and backsplash are 1" thick black epoxy resin. Standard equipment includes a 12" x 8" x 6"D epoxy resin sink with outlet, two cold water gooseneck faucets, two double gas fixtures, two duplex GFCI receptacles. Models with the sink in the peninsula section also include apparatus rod sockets. Apparatus rod assemblies are available separately. Overall size is 90" x 84" x 36"H.

**Model Naming Convention:** PWS (Sink Location: "A" for peninsula, "B" for wall) - (Wall Cabinet Style)(Peninsula Cabinet Style) R

**Model shown above left:** PWSA-2220R

**Model shown above right:** PWSB-2220R

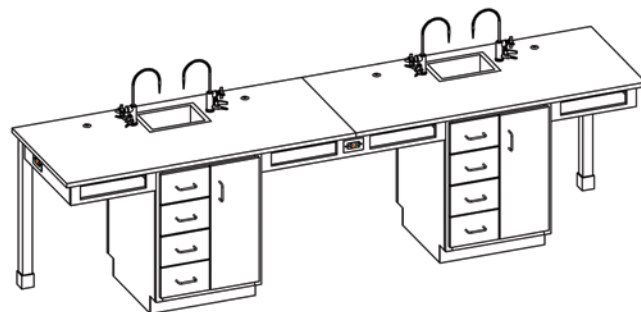
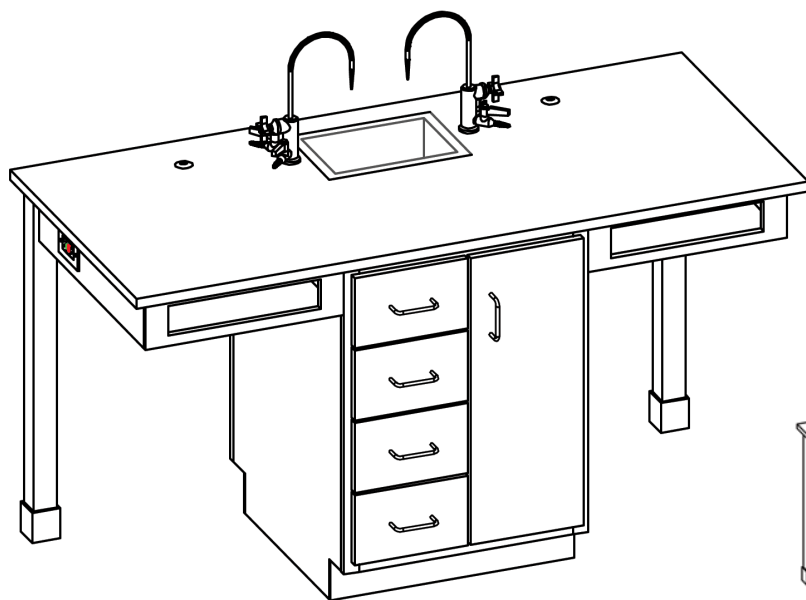

**Two Student Lab Workstation**

A completely self-contained lab island with two work stations. The base includes a center storage cabinet, bookwell aprons, and rear support legs. Supplied with a 1" thick epoxy resin top, 12" x 8" x 6"D epoxy resin sink, two cold water/gas combo faucets, apparatus rod sockets, and two duplex GFCI outlets. Overall size is 72"W x 30"D x 36"H. Multiple units can be ganged together.

**Model Naming Convention:** SD - 2 (Cabinet Style) R - (# of Units)

**Model shown above (main):** SD-227R-1

**Model shown above (small, right):** SD-227R-2

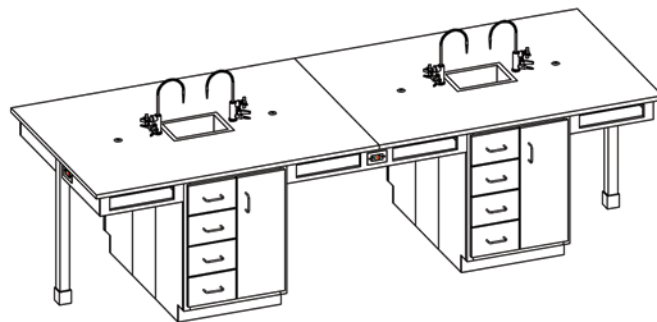
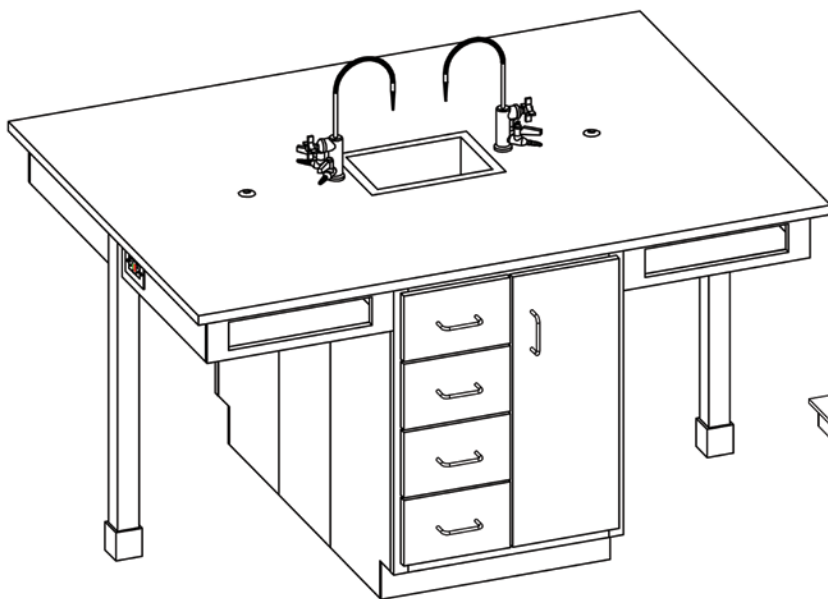

**Four Student Lab Workstation**

Double faced unit with a storage cabinet and bookwells at the front and rear and support legs on the ends. Supplied with a 1" thick epoxy resin top, 12" x 8" x 6"D epoxy resin sink, two cold water/gas combo faucets, apparatus rod sockets, and two duplex GFCI outlets. Overall size is 72"W x 48"D x 36"H. Multiple units can be ganged together.

**Model Naming Convention:** SD - 4 (Cabinet Style) R - (# of Units)

**Model shown above (main):** SD-427R-1

**Model shown above (small, right):** SD-427R-2

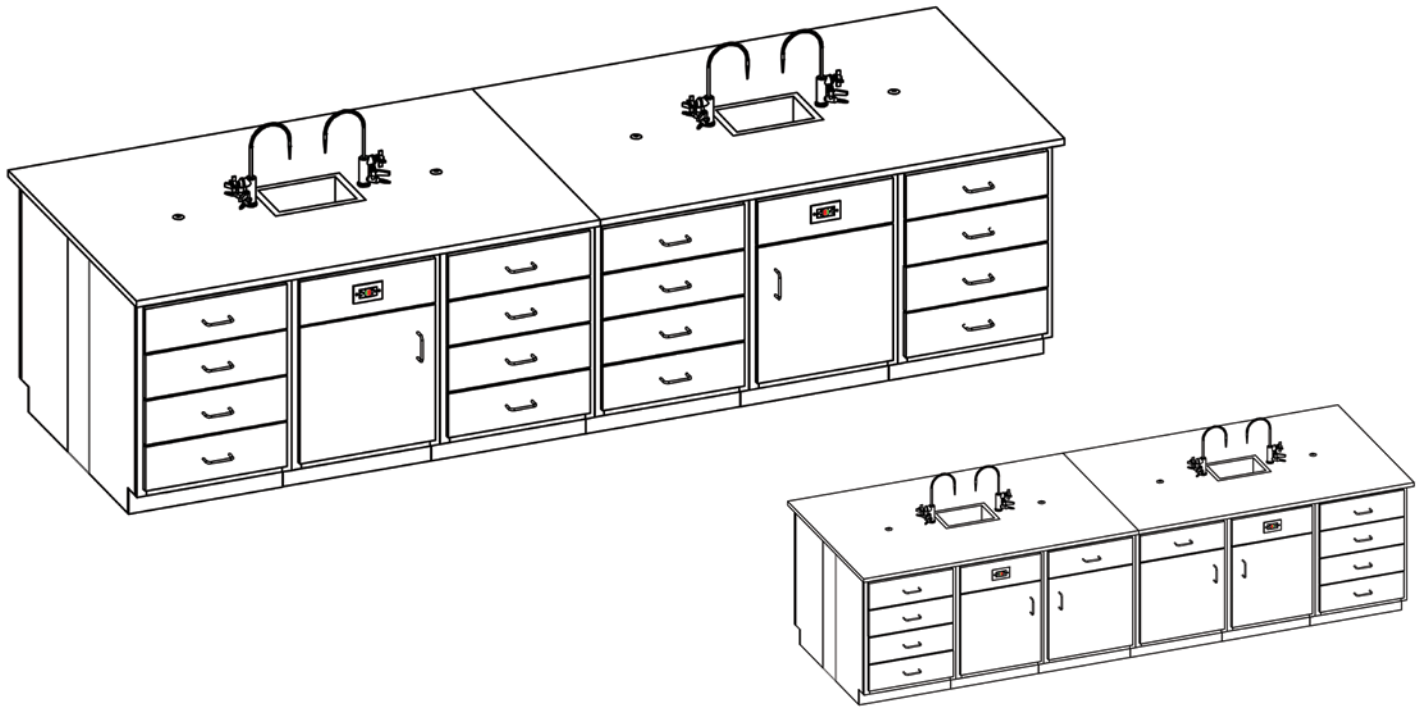

### Island Workstation

This lab island combines a large worksurface with ample storage. Each side of the base consists of (2) sink base cabinets and (4) 24" W storage cabinets. A duplex GFCI is supplied at the top of each sink cabinet. The top is 1" thick epoxy resin. Includes (2) 12" x 8" x 6" D epoxy sinks, (4) cold water/gas combo faucets, and apparatus rod sockets. Overall size is 144" W x 48" D x 36" H.

**Model Naming Convention:** IWS - (Outer Base Cabinet Style)(Inner Base Cabinet Style) R

**Model shown above (main):** IWS-2020R

**Model shown above (small, right):** IWS-2022R

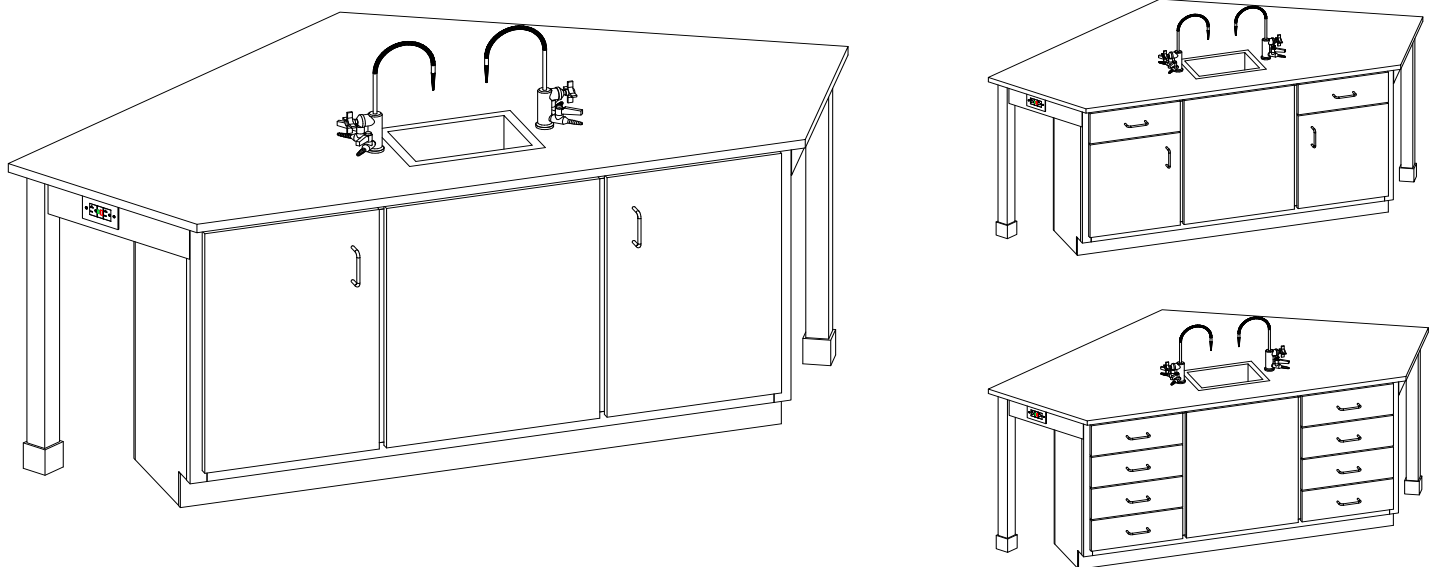

### Four Student Workstation

This workstation features a storage area at the front of the unit and an apron area at the rear of the unit. This configuration allows all four students to face the front of the classroom. Works well as both a lecture and lab workstation. Supplied with a 1" thick epoxy resin top, 12" x 8" x 6" D epoxy resin sink, two cold water/gas combo faucets, and two duplex GFCI outlets. Unit can be modified to include cabinet configurations other than those shown and can also be ordered without sink/faucets. Overall size is 96" W x 48" D x 36" H.

**Model Naming Convention:** LAB4 - (Left Base Cabinet Style)(Right Base Cabinet Style) R

**Model shown above (main):** LAB4-2121R

**Model shown above (small, upper right):** LAB4-2222R

**Model shown above (small, lower right):** LAB4-2020R



**Model HWS-60RS**

See stools on page 9.



**Model HWS-60PE**

### Hexagonal Workstation

High quality six-sided workstations for both science laboratories and classrooms requiring computer stations. Featuring a solid hardwood face frame, the pedestal base conceals utility connections that are accessible through a lockable access panel. The six-sided apron assembly includes bookwells. Drawers are an available option. Standard laboratory configuration includes an epoxy resin sink (12" x 8" x 6" deep), one cold water faucet, and one dual gas fixture. Overall size: 60" x 60" x 36"H.

#### Model HWS-60RS

Also available as a multi-student computer station. Includes a HPL top with centrally located riser with duplex electrical outlet on three sides instead of plumbing fixtures. Shown above w/ custom laminate, black is standard.

#### Model HWS-60PE



### Octagonal Workstation

These octagonal stations allow for easily accessible storage while providing ample legroom on four corners. The unit is supported by a sturdily constructed pedestal. Hanging cabinets are suspended from a solid wood apron assembly and feature heavy duty face frame construction. Top is 1" thick epoxy resin. The workstation is available with either a plain worksurface, sink with cold water/gas combo faucets and apparatus rod sockets, or an electrical turret. Overall size is 60" x 60" x 36"H.

**Model Naming Convention:** OWS - 60R - (Cabinet Style, "PED" for No Suspended Cabinets)(S - Sink, E - Electrical Turret, P - Plain)

**Model shown above (left):** OWS-60R-21S

**Model shown above (right):** OWS-60R-20E

### Epoxy Resin Sinks

Both undermount and drop-in epoxy resin sinks are available in many different shapes and sizes. Some sink sizes are available with an ADA depth. Sinks include polypropylene outlets as standard.

### Faucets and Gas Fixtures

Hann supplies a large variety of faucets and gas fixtures. Ask us about options and configurations.

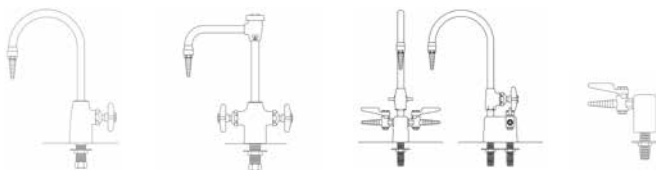

### Apparatus Rods

Aluminum uprights and crossbars are available in 3/4" diameter and various lengths. Accompanying rod sockets and clamps are also available in aluminum.

### Emergency Showers, Eye/Face Washes

Several models and combinations of emergency showers and eye/face washes are offered including barrier-free and handheld versions.

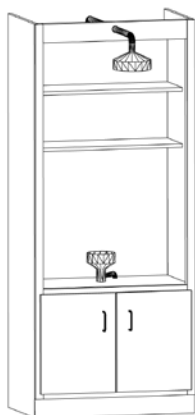

Model SC-3584SC



### Epoxy Resin Pegboards & Drip Troughs

Epoxy resin pegboards are available in several sizes and peg quantities. Pegs are included. Stainless steel drip troughs are also available.

### Goggle Cabinet

Sanitizing cabinet for safety glasses and goggles. Sturdy 24 gauge white enameled steel cabinet. Doors are interlocked with tamper resistant latches. May be mounted on wall or shelf. Includes a seven foot grounded electrical cord. No direct UV radiation escapes from cabinet when in use. Shuts off automatically if doors are opened. Includes pilot light, five minute cycle timer and germicidal lamp. Each of the eight shelves will hold six pairs of glasses or five pairs of goggles. Goggles not included. Cabinet measures 32"H x 24-1/2"W x 9-1/2"D.

Model 90494



### Fume Hoods

Hann offers a full line of fume hoods in several standard sizes and configurations. Some available options include remote water and gas service, receptacles, and blowers.





### Flammable Liquid Storage Cabinet

This safety cabinet features powder coated steel construction and includes two galvanized steel shelves. Total capacity is 45 gallons. Doors are mounted on continuous hinges and utilize three point latches. Cabinet includes vents and leveling feet. Overall size 43"W x 18"D x 65"H.

**Model SAF-FL-1947**, manual closing doors.

**Model SAF-FL-4510**, self-closing doors.



### Polyethylene Waste Cans

These poly cans offer fire safe temporary storage of solvent, waste rags, and other materials subject to spontaneous combustion. Poly material will not dent or rust and is resistant to most chemicals. Cans feature self-closing lid with foot lever.

**Model SAF-OW-933**, 6 gallon capacity

**Model SAF-OW-935**, 10 gallon capacity

**Model SAF-OW-937**, 14 gallon capacity



### Corrosives Storage Cabinet

This safety cabinet features special corrosion resistant powder coated steel construction and includes two shelves. Shelves and bottom are fitted with poly trays. Total capacity is 45 gallons. Doors are mounted on continuous hinges and utilize three point latches. Cabinet includes vents and leveling feet. Not recommended for storage of aggressive acids such as nitric, sulfuric and hydrochloric. Overall size 43"W x 18"D x 65"H.

**Model SAF-CRA-47**, manual closing doors.

**Model SAF-CRA-4510**, self-closing doors.



### Poly Acid Storage Cabinets

These cabinets are constructed of 100% polyethylene and are suited to the storage of aggressive acids. Storage areas in the doors for small bottles. Available in both a 24-gallon under counter and 4-gallon countertop version. The 24-gallon cabinet measures 35"W x 22"D x 36"H and the 4-gallon cabinet measures 18"W x 18"D x 22"H.

**Model SAF-M04CRA**, 4 gallon.

**Model SAF-M24CRA**, 24 gallon.



Multiple-layer face over a dense fiber core with a balancing backer. Provides a 3/4" thick, rock hard, smooth surface.

Common Uses: Drawing/Drafting

## Maple



Pieces of solid hard maple glued together to form an attractive, durable and renewable worksurface. Common thicknesses of 1-3/4" and 2-1/4".

Common Uses: Art Tables, Workbenches



High pressure laminate over an industrial grade particleboard core with balancing backer and coordinating edging. Nominal thickness is 1-1/4". Available in a variety of colors and patterns.

Common Uses: Art Tables, Mobile Demonstration, Life Sciences



Chemically resistant Wilsonart® plastic laminate over a particle board core with balancing backer and coordinating edging. Black is the standard color. Nominal thickness is 1-1/4".

Common Uses: Light Duty Science

## Phenolic resin

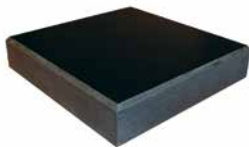

Chemically resistant lab top based on a cellulose fiber reinforced phenolic resin core. Moisture and scratch resistant. Available in 1" and 3/4" thicknesses. Black finish is standard with other limited colors available.

Common Uses: All Sciences

## Epoxy Resin



Monolithic modified epoxy resin is an inert, flat, non-porous surface that is highly resistant to virtually all chemicals found in school labs. Non-glare black finish is standard with other limited colors available. Available in 1" and 3/4" thicknesses.

Common Uses: All Sciences

## Mobile Storage Cabinet Series

These mobile storage cabinets are available in a variety of configurations to suit any storage need. They are ruggedly constructed of hard maple solids and panels and feature front and rear frames. The cabinets include locking doors and move easily on 4" casters. Overall size is 48"W x 22"D x 66"H.



### Shelving Unit

The SC-200M includes three adjustable shelves. Allows for flexible storage of any number of items.

**Model SC-200M**



### Tool Storage Unit

This unit comes complete with pegboard, two full width adjustable shelves, and six tote trays. Great for tool and parts storage.

**Model TS-200M**



### Tote Tray Storage Unit

This mobile storage cabinet efficiently stores student projects and supplies. The SC-230TTM includes one full width shelf and 24 tote trays. The 3/4" overlay doors include master keyed cylinder lock.

**Model SC-230TTM**



### Bin Storage Unit

This supply and storage cabinet is complete with 58 removable hanging bins. Twenty small bins; twenty-one medium bins; fifteen large bins; and two extra large bins. Complete with locking doors.

**Model SC-260TTM**



### Tote Tray/Shelf Storage Unit

A unique combination of tote tray storage with convenient shelf storage. Unit includes two 2/3" wide adjustable shelves, one full length shelf, seven hardboard shelves; eight tote trays and 3/4" overlay doors. Doors include master keyed cylinder lock.

**Model SC-231TTM**



### Teacher's Mobile Storage Cabinet

This unit provides useful storage space for personal items as well as records and classroom supplies. Features two file drawers, one smaller drawer, hanger bar and adjustable shelves. Lockable doors.

**Model SC-211**

**All Purpose Mobile Shop Carts**

These small portable units are ideal for a variety of shop applications, such as woodworking, tech ed, arts & craft areas, and for any of the multiple activities that take place in the elementary classroom. Constructed of maple framing and paneling with natural finish. The 1-3/4" thick maple top can be supplied with optional vises. For all models except WRB-4, right end is fitted with 1/4" pegboard and hooks for tool mounting. Supplied with 4" locking casters.



Complete with two locking doors and adjustable center shelf. Overall size is 36"W x 24"D x 34"H.

**Model WRB-1**



Supplied with two locking drawers, double locking doors with adjustable shelf. Overall size is 36"W x 24"D x 34"H.

**Model WRB-2**



Complete with three locking drawers and locking door with adjustable shelf. Overall size is 36"W x 24"D x 34"H.

**Model WRB-7**



Complete with two locking doors and adjustable center shelf. Overall size is 60"W x 30"D x 34"H.

**Model WRB-4**

**Mobile Tote Tray Units**

Hann Manufacturing's tote tray cabinets are ideal for the arts and crafts room or lab. Mounted on 4" casters, they can be rolled out of the way when not in use. Units are constructed of maple framing and panels.



Cabinet with 24 tote trays. 48"W x 22"D x 46"H.

**Model SC-4824**



Cabinet with 15 trays. 48"W x 22"D x 33"H.

**Model SC-3415**

Same as above with locking doors.

**Model SC-4824WD**

**Elementary Mobile Workbench**

Completely flexible. Can be moved from room to room to assist with multiple activities. Two sloping pegboard panels and one on each end provide lots of space for storage in addition to the double door cabinet with adjustable shelf. Hard maple framing and panel construction includes locking casters and two boxes of assorted pegboard hooks.



Cabinet is 47"W x 22"D. Maple top is 1-3/4" x 28" x 60". Overall height is 28-1/2".

**Model EP-6B**



SC-10 Storage Case



SC-21 Storage Case

**General Storage Cases**

This series of solidly constructed hardwood cabinets is designed for general usage in both crafts and industrial arts areas. All units constructed of hard maple framing and hardwood paneling. Natural finish. Each unit furnished with master keyed locks.

The SC-10 is equipped with five adjustable shelves on the left side and a fixed center shelf with four adjustable shelves on the right side. Large compartment shelves are 39" x 19", adjustable on 1/2" centers. Overall size is 60"W x 22"D x 84"H.

**Model SC-10**

The SC-11 provides one fixed and four adjustable shelves approximately 58" x 19", adjustable on 1/2" centers. Shelves have center bracket for additional support. Overall size is 60"W x 22"D x 84"H.

**Model SC-11**

The SC-21 case provides one fixed and four adjustable shelves approximately 46" x 19". Overall size is 48"W x 22"D x 84"H.

**Model SC-21**

Similar to the SC-21, but smaller. Shelves are approximately 22" x 19". Overall size is 24"W x 22"D x 84"H.

**Model SC-24**

Shelves are approximately 28" x 19". Overall size is 30"W x 22"D x 84"H.

**Model SC-31**

Shelves are approximately 33" x 19". Overall size is 35"W x 22"D x 84"H.

**Model SC-35**



**Open Storage Cabinets**

Same quality construction as cabinets with doors using maple solids and panels. Tall cabinets have four adjustable shelves and a fixed center shelf. Short open cabinets have two adjustable shelves.

48"W x 12"D x 84"H

**Model OSC-48**

36"W x 12"D x 84"H

**Model OSC-36**

Open storage cabinets also available in 16" depth.

48"W x 12"D x 36"H

**Model OBC-48**

36"W x 12"D x 36"H

**Model OBC-36**

Open base cabinets are for use under a counter. Tops are **not** included.

**General Purpose Storage Cabinet**

This storage cabinet comes complete with four adjustable shelves. Construction is hard maple framing and plywood throughout, with natural finish. Complete with master keyed cylinder lock. Overall size is 36"W x 18"D x 84"H.

**Model SC-1B**



**Reference Material Cabinet**

This Hann cabinet is ideal for storage and display of projects, books, magazines, trophies and more. Upper cabinet provides two adjustable glass shelves and 1/4" tempered glass sliding doors. Lower right storage area includes two shelves 42"W x 19"D. Three large filing drawers at left provide reference storage. Locks are provided for storage areas and file drawers. Cabinet is constructed of heavy duty maple framing and panels. Natural finish. Overall size is 60"W x 22"D x 84"H.  
**Model SC-13G**



**General Storage Cabinet**

This cabinet will meet almost any storage requirement. Includes four shelves in upper storage area with two large cupboard doors. Each shelf is adjustable, size 45"W x 19"D. Four lower drawers are each 21"D. Constructed of hard maple framing and panels. Overall size is 48"W x 22"D x 84"H.  
**Model TS-2**

Same general storage cabinet as above, but with a center dividing partition in the upper section resulting in eight smaller, separated adjustable shelves.  
**Model TS-8**



**Wardrobe Case**

Cabinet features full shelf for hats, half-width garment rod and three storage shelves at left. Lock included. Overall size is 27"W x 22"D x 84"H  
**Model SC-32**

Similar to the SC-32, but 48" wide.  
**Model SC-21CW**

**Tote Tray Storage Cabinets**

A storage solution for multiple activities. All cabinets constructed of maple solids and panels. Includes lock for security. Natural finish. Tote trays are constructed of high-impact polystyrene and include label holders. Tray inside dimensions are approximately 12-1/2"W x 18"D x 3-1/2"H. Overall size is 48"W x 22"D x 84"H.



Cabinet with 48 tote trays.  
**Model TT-3**



Cabinet with 24 tote trays and three adjustable shelves.  
**Model TT-4**



Cabinet with 24 tote trays and upper compartment lined with pegboard.  
**Model TT-5**

## Tote Tray Storage Cabinets

This tote tray cabinet series is offered in several configurations and includes sturdy adjustable plywood shelving for flexible long term use. The tote trays are constructed of high-impact polystyrene and include label holders. Tray inside dimensions are approximately 11-1/2"W x 16"D x 3"H.



### Tote Tray Storage Cabinet

This cabinet includes (51) tote trays. The center shelf is fixed and all others are adjustable. Overall size is 48"W x 22"D x 84"H.

**Model TT-482284-51T**



### Tote Tray & Tote Caddy Storage Cabinet

Includes (36) tote trays and (6) tote caddies. Lower tote tray shelf is fixed and all others are adjustable. Overall size is 48"W x 22"D x 84"H.

**Model TT-482284-36T6C**



### Tote Tray Garage Cabinet

This cabinet includes (8) adjustable shelves and (27) tote trays in the upper section. The bottom section of the cabinet acts as a garage for mobile tote tray carts or any other type of mobile cart. The garage space is 45"W x 19"D x 35"H. Overall size is 48"W x 22"D x 84"H.

**Model TTG-482284-27T**

Tote tray garage cabinet with MSTT-212W mobile tote tray cart shown at right. Works great for student storage in the upper trays and project storage in the larger lower trays.

**Model TTG-482284-27T-212W**



### Mobile Tote Tray Cart

Holds (12) wide tote trays with approximate inside dimensions of 16"W x 16"D x 3"H. Sturdy cart features fully welded front and rear steel frames. Tote tray runners allow trays to be partially opened and accessed without falling out. Cart's lipped top is perfect for transporting additional tote trays and supplies. Overall size is 41"W x 17"D x 29"H.

**Model MSTT-212W**



**Deeper Modular Tool Storage Cabinet**

The ultimate tool organizer. Pegboard panels line the back and the inside of doors for increased tool storage capacity. Also includes one adjustable shelf and four tote trays (8" x 19" x 3-1/2"). Cabinet includes lock. Natural finish. Tools not included. Comes with peg hook sets. Overall size is 36"W x 22"D x 84"H.

**Model TS-1000**



**Large Capacity Tool Storage Cabinet**

An economical way to provide security for tools and parts. Complete with 1/4" pegboard lined back, two adjustable shelves and ten plastic bins. Constructed of hard maple framing and paneling with natural finish. Includes master keyed cylinder lock. Comes with peg hook sets. Overall size is 36"W x 18"D x 84"H.

**Model TS-36W**



**Parts Storage Cabinet**

Cabinet is complete with 80 plastic hang bins (4"W x 3"D x 8"L) and three adjustable shelves. Construction is hard maple framing and plywood throughout, with natural finish. Complete with master keyed cylinder lock. Overall size is 36"W x 18"D x 84"H.

**Model PSC-18**



**Flexible Tool Storage Cabinet**

Cabinet provides great flexibility in tool storage. Entire back of cabinet is lined with 1/4" pegboard and is supplied with an assortment of tool hooks. Cabinet is constructed of hard maple framing and paneling with natural finish. Includes master keyed cylinder lock. Overall is 36"W x 18"D x 84"H.

**Model TS-44W**



**Adjustable Shelf Storage Cabinet**

This model provides 1/4" pegboard lined back and four adjustable shelves for tools too large to hang. Complete with an assortment of tool hangers. Constructed of heavy maple framing and paneling with natural finish. Includes master keyed cylinder lock. Overall size is 36"W x 18"D x 84"H.

**Model TS-48W**



**Power Tool Storage Cabinet**

The BC-180WT provides plenty of storage space for your power tools. The cabinet features four large drawers each 13-7/8"W x 18-5/8"D x 5-3/8"H. The roomy cabinet area includes two large suspension shelves providing three storage areas each 9" high. Drawers and doors are furnished with master keyed locks. Top is 48"W x 24"D x 1-3/4" thick maple. Overall height is 36-1/2" with top.

**Model BC-180WT**

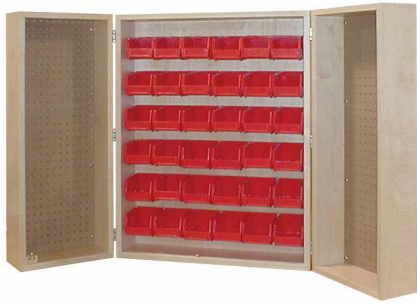

**56" Wall Mounted Parts Storage**

Stores parts neatly and conveniently. The cabinet features 36 removable parts trays and door sections fitted with pegboard. Constructed of solid maple framing and maple panels with natural finish. Doors mounted on continuous hinges and include lock. Center panel is 28"W x 6"D x 32"H. A 56" wide storage area is provided when unit is open. Overall size of the closed unit is 28"W x 12"D x 33"H.

**Model PC-936**



**56" Wall Mounted Tool Storage**

This unit gives you 56"W continuous tool mounting area when open. Constructed of solid maple framing and maple panels with natural finish. Interior is fitted with pegboard. Doors mounted on continuous hinges and include lock. Furnished with an assortment of tool hangers. Center panel is 26"W x 6"D x 32"H, and each side panel is 14"W x 6"D x 32"H. Overall size of the closed unit is 28"W x 12"D x 33"H.

**Model TC-9**



**96" Wall Mounted Tool Storage**

This cabinet provides 96" of tool mounting area when the unit is open. Constructed of solid maple framing and maple panels with natural finish. Interior is fitted with pegboard. Doors mounted on continuous hinges and include lock. Furnished with an assortment of tool hangers. Side panels are 24"W x 4"D x 48"H and center panel is 48"W x 4"D x 48"H.

**Model TC-5**

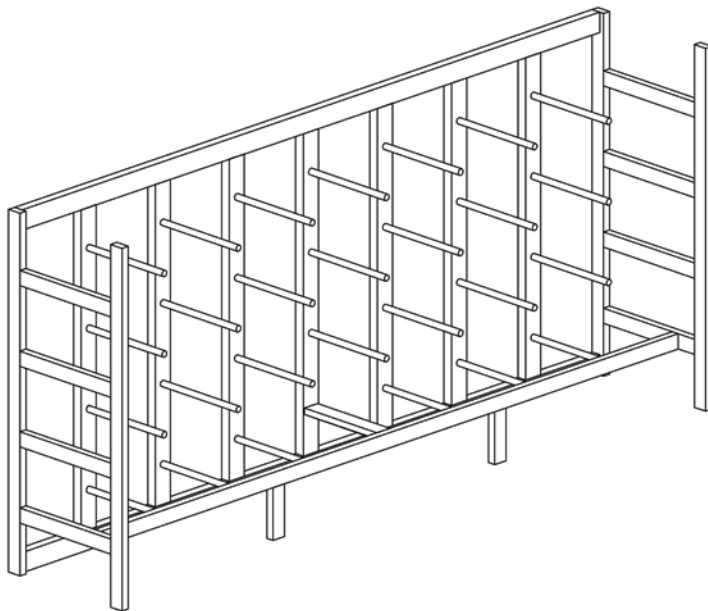

**Lumber Rack**

Solid hard maple frame features sturdy mortise and tenon joints with bolt reinforcement. The unit is self supporting. Rear uprights are 2" x 4" and each holds four 1" pipe support arms. Overall size is 156"W x 32"D x 72"H.

**Model L-2**

**Wall Mounted Storage Rack**

Hann's wall mounting storage rack is constructed of 2" x 4" hard maple. The storage rack includes ten openings for support arms. Rack is furnished with five solid 1" pipe arms, but will accommodate up to ten. Recommended spacing between uprights is 2'. The basic upright is designed for mounting directly to wall, but two optional heavy steel brackets can be ordered to space the upright 16" from wall. These brackets anchor the top and bottom to wall, thus offering an excellent plywood storage area in between. Overall height is 84".



**Model L-10** One upright

**Model L-20** Two uprights

**Model L-30** Three uprights

**Model L-40** Four uprights

**Model L-50** Five uprights

**Model L-60** Six uprights

**Model L-70** Seven Uprights

**Model L-80** Eight Uprights

**Model L-90** Nine Uprights

**Model L-8** Extra Arm

**Model L-9** Pair of 16" wall spacer brackets

## Trade Tool Storage Cabinets

Hann Manufacturing offers a complete line of tool storage cabinets designed to accommodate specific tools. The cabinets are built using solid hard maple and maple plywood. Heavy-duty construction features 1-1/2" thick mortise and tenon face frames, doors mounted on continuous hinges, and 3/4" thick plywood backs. The lower cabinet area consists of two adjustable shelves and is equipped with eight large tote trays and ten small bins. Upper compartment is configured with either dedicated tool holders or pegboard. Overall dimensions are 60"W x 22"D x 84"H.



### Tool Storage Cabinet Shell Only

The basic cabinet without pegboard or dedicated tool holders. Tote trays not included. Ready to be outfitted for your specific tool storage needs.

**Model TS-5**

### Tool Storage Cabinet With Pegboard

This version of the tool storage cabinet includes pegboard lining the interior of the upper compartment and upper doors. Pegboard hook assortment is included.

**Model TS-4**





#### Woodworking Tool Storage Cabinet

The upper compartment and doors are lined with dedicated tool holders to accommodate woodworking tools. See page 49 for construction details. Contact us for a detailed tool list.

**Model TS-10 (no tools, holders only)**

**Model TS-10WT (includes tools)**

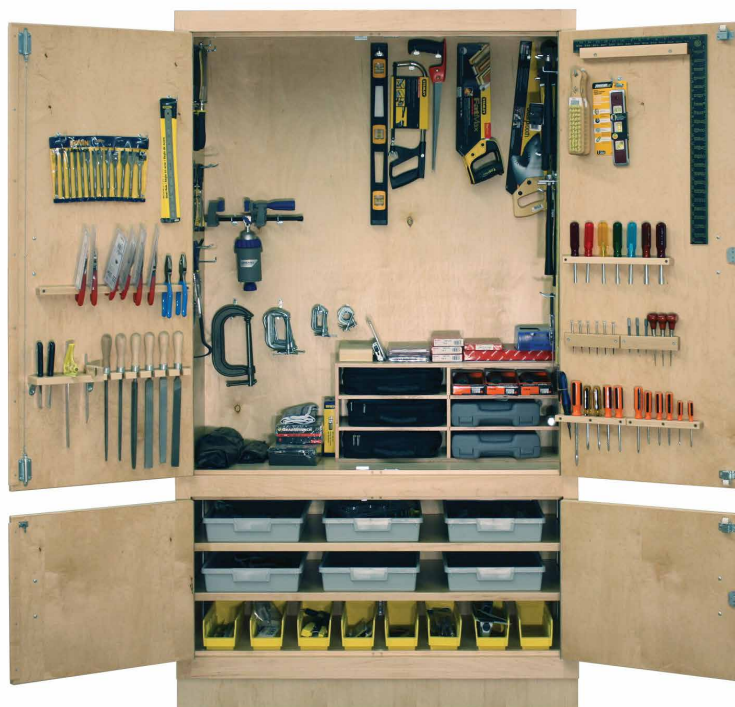

#### 48"W Woodworking Tool Storage Cabinet

A narrower version of the woodworking tool storage cabinet. See page 49 for construction details. Contact us for a detailed tool list.

**Model TS-40 (no tools, holders only)**

**Model TS-40WT (includes tools)**

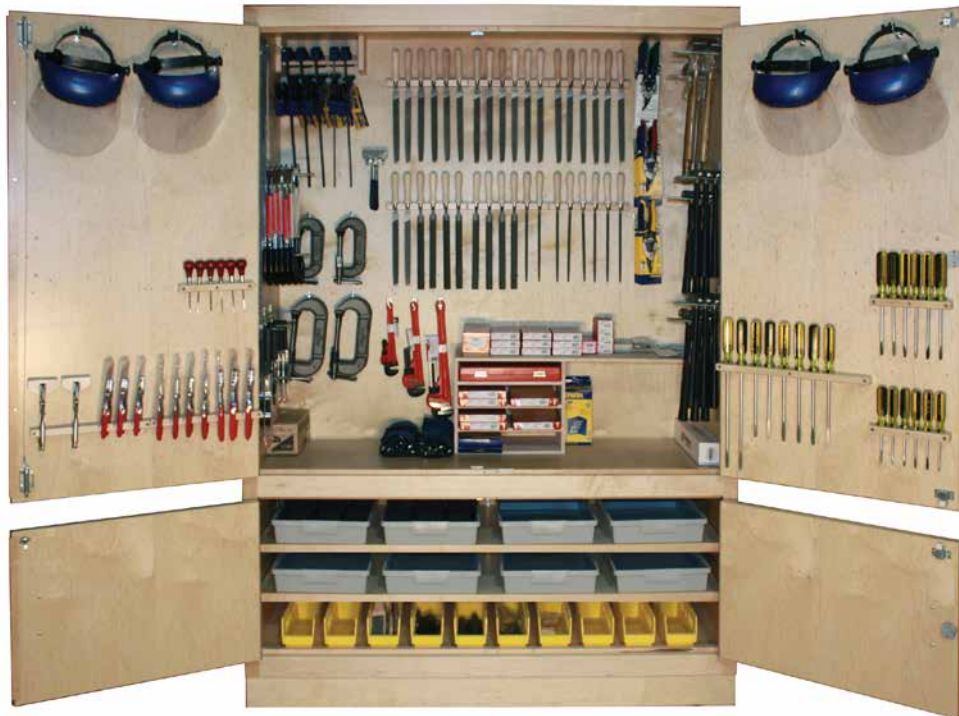

#### **Metalworking Tool Storage Cabinet**

The upper compartment and doors are lined with dedicated tool holders to accommodate metalworking tools. See page 49 for construction details. Contact us for a detailed tool list.

**Model TS-11 (no tools, holders only)**

**Model TS-11WT (includes tools)**



#### **General Construction Tool Storage Cabinet**

The upper compartment and doors are lined with dedicated tool holders to accommodate construction tools. See page 49 for construction details. Contact us for a detailed tool list.

**Model TS-12 (no tools, holders only)**

**Model TS-12WT (includes tools)**



**Maple Tops 1-3/4" or 2-1/4"**

These maple bench tops are manufactured of the finest grade northern grown maple. The lumber is seasoned and then kiln-dried to a moisture content of six to eight percent. Strips of lumber are then electronically laminated with a special tight bonding glue to create a smooth surface. The tops are finished to a thickness of 1-3/4" or 2-1/4". Natural finish.

<u>Top Size</u>	<u>1-3/4" Thick</u>	<u>2-1/4" Thick</u>
24" x 48"	72448	92448
24" x 60"	72460	92460
24" x 72"	72472	92472
24" x 96"	72496	92496
24" x 120"	724120	924120
24" x 144"	724144	924144
30" x 48"	73048	93048
30" x 60"	73060	93060
30" x 72"	73072	93072
30" x 96"	73096	93096
30" x 120"	730120	930120
30" x 144"	730144	930144
36" x 48"	73648	93648
36" x 60"	73660	93660
36" x 72"	73672	93672
36" x 96"	73696	93696
36" x 120"	736120	936120
36" x 144"	736144	936144

**Maple Back and End Stops**

Back and end stops are available to fit any top length or thickness. Constructed of 3/4" solid maple, the curbs are pre-drilled and complete with fasteners. Increases overall top height 4". End stops increase overall length by 1-1/2".

**Back Stops**

60" W	<b>Model WBS-60</b>
72" W	<b>Model WBS-72</b>

**End Stops**

24" W	<b>Model WES-24</b>
30" W	<b>Model WES-30</b>

**Risers**

Risers mount easily to top of workbench and inside of end stops. Provides a handy shelf for tools or parts. Maple supports with edgebanded shelf.

60"W	<b>Model WRS-60</b>
72"W	<b>Model WRS-72</b>
96"W	<b>Model WRS-96</b>

**Iron Edges**

Painted angle iron edges can be fitted flush to any bench top edge. Iron size is 2"W x 2"D x 1/8" thick.

**Cederquist Joint Fasteners**

Our maple tops can be manufactured in many different arrangements to suit individual classroom needs. Cederquist joint fasteners permit tightening of the joint assemblies and can be ordered for any application. Generally we recommend one fastener across each 12" of bench top. Thus a 24" wide top would require two fasteners. Drilling of holes beneath top included.

**Model CQ Fastener**

Shown to the right are two of the many arrangements you could choose for your classroom, fastened together with Cederquist joint fasteners.

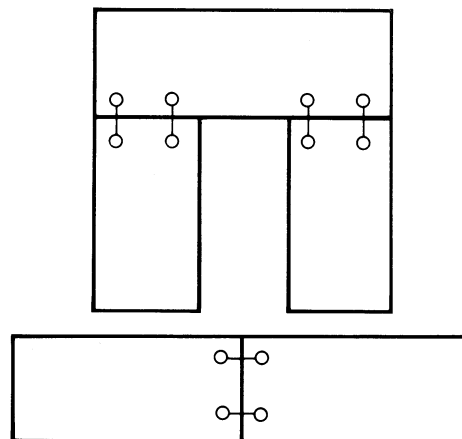

## Project Bench Series

Hann's four station benches are ideal for use in a STEM lab, art studio, or any project space. Maple top is 54" x 64" x 2-1/4" thick. Bases are made of heavy maple framing and hardwood paneling with natural finish. Overall height is 33-1/4". To add versatility, optional woodworking vises can be supplied.



The LCB-30 base consists of two 6-drawer cabinets (35"W x 22"D x 31"H) placed back-to-back.

**Model LCB-30-0V** - No Vises

**Model LCB-30-4V** - (4) Vises



The LCB-31 base consists of two double-door cabinets (35"W x 22"D x 31"H) placed back-to-back.

**Model LCB-31-0V** - No Vises

**Model LCB-31-4V** - (4) Vises



The LCB-32 base consists of two cabinets, each w/ (2)-drawers above double-doors (35"W x 22"D x 31"H), placed back-to-back.

**Model LCB-32-0V** - No Vises

**Model LCB-32-4V** - (4) Vises



The LCB-37 base consists of two cabinets, each w/ (3)-drawers beside a single door (35"W x 22"D x 31"H), placed back-to-back.

**Model LCB-37-0V** - No Vises

**Model LCB-37-4V** - (4) Vises



The LCBL-4 base consists of two cabinets, each w/ (6) doors (35"W x 22"D x 31"H), placed back-to-back.

**Model LCBL-4-0V** - No Vises

**Model LCBL-4-4V** - (4) Vises



**Eight Student Workstation**

This unit can serve as a training module or project center for up to eight students. Each wing provides workspace while the center allows space for parts and materials. The 2-1/4" hard maple top includes a center octagonal section that measures 56" across and (4) wings which are all 32"W x 30"D. The top overhangs the base cabinets by roughly 4" on all sides. The base cabinets all feature our heavy-duty solid hard maple face frame construction. The base cabinet under each wing includes an adjustable shelf. The drawer cabinets in the center include (3) drawers. The upper drawers measure 16"W x 13"D x 4"H (I.D.) and the lower drawer measures 16"W x 13"D x 8"H (I.D.). Overall height is 32".

**Model WB8-31**

**Wall Benches**

Hann's complete series of wall benches are available in a variety of base configurations and top styles to suit any requirement. Wall benches are sturdily constructed of hard maple framing and hardwood paneling with natural finish. All drawers feature dovetail construction. Optional cylinder locks can be furnished. BC-30 base cabinets have six drawers. BC-37 base cabinets have three drawers and one door and the BC-31 bases have two doors. Available with a 1-3/4" thick or 2-1/4" thick maple top. Ask us about additional cabinet and top options.



**WTB-10L**



**WBB-10L**



**WWB-6L**

**WTB Series**

Top Size	1-3/4" Top	2-1/4" Top
24" x 72", (2) BC-30	<b>WTB-6L</b>	<b>WTB-6</b>
24" x 96", (2) BC-30	<b>WTB-8L</b>	<b>WTB-8</b>
24" x 120", (3) BC-30	<b>WTB-10L</b>	<b>WTB-10</b>
24" x 144", (4) BC-30	<b>WTB-12L</b>	<b>WTB-12</b>

**WBB Series**

Top Size	1-3/4" Top	2-1/4" Top
24" x 72", (2) BC-37	<b>WBB-6L</b>	<b>WBB-6</b>
24" x 96", (2) BC-37	<b>WBB-8L</b>	<b>WBB-8</b>
24" x 120", (3) BC-37	<b>WBB-10L</b>	<b>WBB-10</b>
24" x 144", (4) BC-37	<b>WBB-12L</b>	<b>WBB-12</b>

**WWB Series**

Top Size	1-3/4" Top	2-1/4" Top
24" x 72", (2) BC-31	<b>WWB-6L</b>	<b>WWB-6</b>
24" x 96", (2) BC-31	<b>WWB-8L</b>	<b>WWB-8</b>
24" x 120", (3) BC-31	<b>WWB-10L</b>	<b>WWB-10</b>
24" x 144", (4) BC-31	<b>WWB-12L</b>	<b>WWB-12</b>



Shown w/ Optional Riser & Curbs



**Cabinet Base Workbench**

A hardworking series of benches for general use. Includes two maple base cabinets: (1) BC-10 and (1) BC-11. Available with three different tops: 1-1/4" thick HPL, 1-3/4" thick maple, or 2-1/4" thick maple. Overall height is cabinet height plus top thickness.

Options include riser, curbs, and locks.  
See page 17 for additional base cabinet options.

Top Size	1-1/4" Top	1-3/4" Top	2-1/4" Top
24" x 60"	<b>W-5404</b>	<b>W-8404</b>	<b>W-7404</b>
30" x 60"	<b>W-5406</b>	<b>W-8406</b>	<b>W-7406</b>
30" x 72"	<b>W-5407</b>	<b>W-8407</b>	<b>W-7407</b>

**Cabinet Base Workbench w/ Angle Iron Top**

Models offer several maple base cabinet configurations. The 2-1/4" thick hard maple top includes angle iron on front edge and a 4"H rear maple curb. Overall height is cabinet height plus 2-1/4".

See page 17 for additional base cabinet options.

Top Size	18"W x 29"H Cabinets	24"W x 35"H Cabinets
24" x 72"	(2) BC-10 / <b>AB-600</b>	(2) BC-120 / <b>AB-650</b>
24" x 72"	(2) BC-11 / <b>AB-601</b>	(2) BC-121 / <b>AB-651</b>
24" x 96"	(3) BC-10 / <b>AB-800</b>	(3) BC-120 / <b>AB-850</b>
24" x 96"	(3) BC-11 / <b>AB-801</b>	(3) BC-121 / <b>AB-851</b>
24" x 120"	(4) BC-10 / <b>AB-1000</b>	(3) BC-120 / <b>AB-1050</b>
24" x 120"	(4) BC-11 / <b>AB-1001</b>	(3) BC-121 / <b>AB-1051</b>



**Open Leg Workbench w/ Angle Iron Top**

These Hann benches are available in either wall or island type models. Tops are 2-1/4" thick laminated maple. Legs are 2-1/4" square maple with bolt reinforcements at all stringers. Includes lower shelf. Wall bench series include 24"D top with angle iron along front edge and 4"H rear maple curb. Lower shelf is 12"D with rear curb. Island bench series include 36"D top with plain edges and no angle iron or rear curb. Lower shelf is 24"D. All benches are shipped with assembly hardware. Natural finish.

**Wall Series**  
**24"D, 32"H**

72"W top.	<b>Model AB-632</b>
96"W top.	<b>Model AB-832</b>
120"W top.	<b>Model AB-1032</b>
144"W top.	<b>Model AB-1232</b>

**24"D, 36-1/2"H**

72"W top.	<b>Model AB-637</b>
96"W top.	<b>Model AB-837</b>
120"W top.	<b>Model AB-1037</b>
144"W top.	<b>Model AB-1237</b>

**Island Series**  
**36"D, 32"H**

72"W top.	<b>Model AB-633</b>
96"W top.	<b>Model AB-833</b>
120"W top.	<b>Model AB-1033</b>
144"W top.	<b>Model AB-1233</b>

**36"D, 36-1/2"H**

72"W top.	<b>Model AB-638</b>
96"W top.	<b>Model AB-838</b>
120"W top.	<b>Model AB-1038</b>
144"W top.	<b>Model AB-1238</b>



W-2315



W-6000

**Construction / Assembly Benches**

Solid hard maple open leg based workbench. All models include four legs, lower shelf, and rear stringer. Maple top available in two thicknesses. Deluxe models include all optional accessories: back and end stops, risers, and drawers. Overall height is 29-3/4" plus top thickness.

Top Size	1-3/4" Top	1-3/4" Deluxe	2-1/4" Top	2-1/4" Deluxe
24" x 48"	W-2310		W-4310	
24" x 60"	W-2311		W-4311	
24" x 72"	W-2312		W-4312	
24" x 96"	W-2309		W-4309	
30" x 48"	W-2313		W-4313	
30" x 60"	W-2314		W-4314	
30" x 72"	W-2315	W-6000	W-4315	W-8000
30" x 96"	W-2316		W-4316	



WL4-4V



WL5-0V

**Four Student Woodworking Bench**

The base is constructed of solid northern grown hard maple. The hard maple top is 2-1/4" x 64"W x 54"D. Leg frame provides a sturdy foundation and lower solid maple slat shelf provides ample storage area. Also available with plywood shelf. Overall height is 32".

Bench with four vises.  
Bench without vises.

**Model WL4-4V**  
**Model WL4-0V**

**Two Student Woodworking Bench**

The two station version of the WL4 bench. Constructed of hard maple and natural finish. Top size is 64"W x 28"D x 2-1/4" thick. Overall height is 32".

Bench with two vises.  
Bench with one vise.  
Bench without vises.

**Model WL5-2V**  
**Model WL5-1V**  
**Model WL5-0V**



M-2312



M-2315-S

**Heavy Duty Industrial Benches**

Sturdy steel open leg assemblies are welded throughout. Includes lower steel shelf and support brace. Finished in gray enamel. Available with either a 1-3/4" thick maple top or a steel top comprised of a 12 gauge steel cap over a 2" wood core. All benches are 34" high.

<u>Top Size</u>	<u>1-3/4" Maple Top</u>	<u>2" Steel Cap Top</u>
24" x 60"	M-2311	M-2311-S
24" x 72"	M-2312	M-2312-S
30" x 60"	M-2314	M-2314-S
30" x 72"	M-2315	M-2315-S
36" x 60"	M-2317	M-2317-S
36" x 72"	M-2318	M-2318-S



ML4-4V



ML4-0V

**Multi-Purpose Four Station Workbench**

This heavy duty workbench includes a 2-1/4" thick hard maple top. The steel base includes lower braces. Lower shelf is an available option. Overall size is 64"W x 54"D x 34-1/4"H.

- Bench with four vises           **Model ML4-4V**
- Bench without vises           **Model ML4-0V**
- Bench with lower shelf       **Model ML4-LS-0V**

**Two Station Workbench**

Scaled down version of the ML4. Overall size is 64"W x 28"D x 34-1/4"H.

- Bench with two vises           **Model ML5-2V**
- Bench with one vise           **Model ML5-1V**
- Bench without vises           **Model ML5-0V**



SFT-FW-3060M-36C

**Tubular Steel Worktables**

This table series is constructed from 12 ga, 2” square tubular steel. Available either as fully welded or knock-down assembly. Base is finished in black. Several top options to choose from. Furnished with adjustable glides as standard, locking casters are an available option.

**Model Number Format:** SFT - (Welded/KD) - (TopType) - (Height)(Options)

**Top Types**

- 1-1/4” x 30” x 60” Black HPL - ‘3060PBK’
- 1-1/4” x 30” x 72” Black HPL - ‘3072PBK’
- 1-3/4” x 30” x 60” Hard Maple - ‘3060M’
- 1-3/4” x 30” x 72” Hard Maple - ‘3072M’
- 1” x 30” x 60” Black Phenolic Resin - ‘3060T’
- 1” x 30” x 72” Black Phenolic Resin - ‘3072T’

**Construction**

- Fully Welded - ‘FW’
- Knock-Down - ‘KD’

**Overall Height (Approx.)**

- 30” - Standard (no suffix)
- 36” - ‘36’

**Options**

- Locking Casters - ‘C’

**Example Model Numbers:**

- SFT-FW-3072PBK-36C - Fully welded frame, 1-1/4” x 30” x 72” black HPL top, 36” overall height, locking casters
- SFT-KD-3060M - Knock-down frame construction, 1-3/4” x 30” x 60” hard maple top, 30” overall height, no casters



MAH-2314-C

**Adjustable Height Steel Leg Workbenches**

This sturdy workbench is constructed from steel channel. Telescoping legs can be adjusted for a overall height of 26” to 36”. The base includes a rear brace and lower shelf. Finished in gray. The 1-3/4” thick hard maple top is available in multiple sizes. Furnished with adjustable glides as standard, locking casters are an available option.

**Model Number Format:** MAH - (Top Size) - (Options)

**Top Sizes**

- 1-3/4” x 30” x 60” Hard Maple - ‘2314’
- 1-3/4” x 30” x 72” Hard Maple - ‘2315’

**Options**

- Locking Casters - ‘C’

**Example Model Numbers:**

- MAH-2314-C - 1-3/4” x 30” x 60” hard maple top, locking casters
- MAH-2315 - 1-3/4” x 30” x 72” hard maple top, adjustable glides



**Modular Steel Bases**

A comprehensive and flexible line of steel base units. Bases are 21”D x 31”H and available in widths of 12”, 18”, 24” and 36”. Standard color is gray. Other colors are available. Optional risers can be added to any unit to increase height to 35”. Additional options include vented doors and master-keyed cylinder locks. Don’t see what you’re looking for? Give us a call for additional configurations and sizes.

**36" Wide Bases**

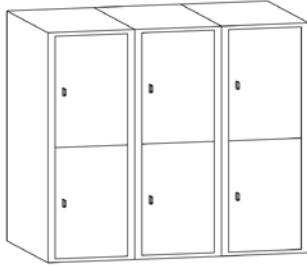

Includes six locker openings (12”W x 21”D x 15”H), spring hinges, padlock hasps and provision for cylinder locks. Double wall construction.  
**Model L-5**

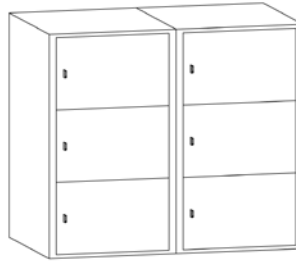

Consists of six locker openings (18”W x 21”D x 10”H), spring hinges, padlock hasp and provision for cylinder locks. Double wall construction.  
**Model L-5A**

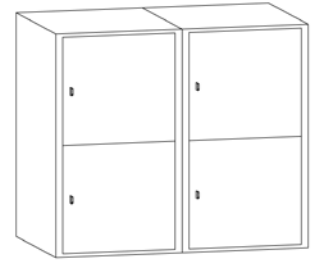

Includes four locker openings (18”W x 21”D x 15”H), spring hinges, padlock hasps, and provision for cylinder lock.  
**Model L-5B**

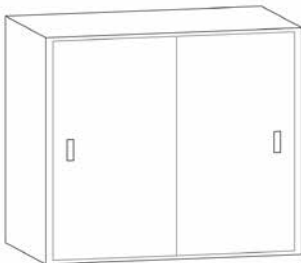

Includes a set of sliding doors on nylon rollers, adjustable center shelf and master keyed lock.  
**Model SD-5**

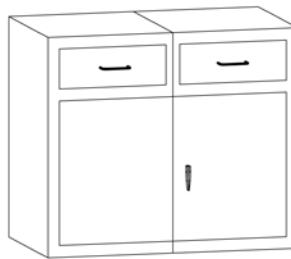

Double door cupboard with two drawers above.  
**Model L-5C**

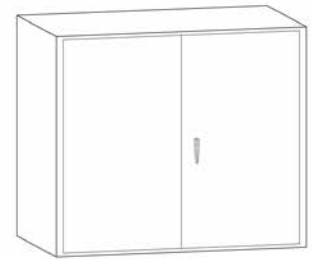

Features double door base with adjustable shelf and master keyed locking handle.  
**Model DD-5**

**18" Wide Bases**



Includes four drawers (14-3/4”W x 19-1/2”D x 5-5/8”H) on nylon rollers with pull, padlock hasp and provision for cylinder lock.  
**Model FD-1**

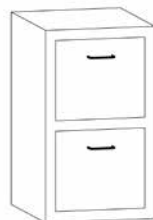

Furnished with two large drawers (14-3/4”W x 19-5/8”D x 13-1/2”H), pull, padlock hasp and provision for cylinder lock.  
**Model FD-2**

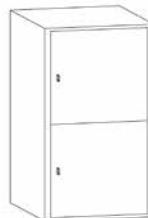

Includes two lockers (18”W x 21”D x 15”H), spring hinges, padlock hasps and provision for cylinder lock.  
**Model L5B2**

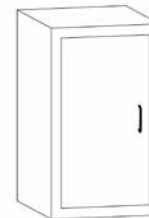

A single door cabinet with adjustable shelf, padlock hasp and provision for cylinder lock.  
**Model DD-1**

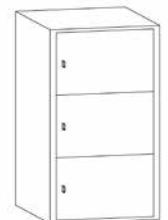

Consists of three lockers (18”W x 21”D x 10”H). Each locker includes spring hinges, padlock hasp and provision for cylinder lock.  
**Model L5A3**



**Single & Double Station Workbenches**

These benches include a solid 2-1/4" thick laminated maple top, size 64"W x 28"D. All base units (36"W x 21"D x 31"H) are constructed of heavy gauge steel. Overall working height is 33-1/4". Woodworking vises are an available option. Standard color is gray with optional colors available. Master keyed cylinder locks are optional.

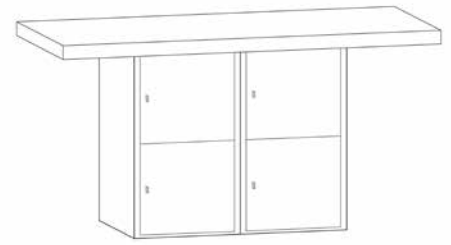
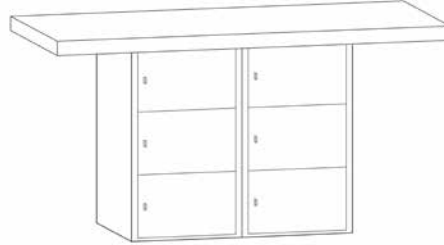
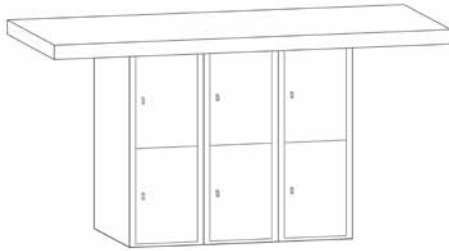

**L5 Series**

Base includes six locker openings (12"W x 21"D x 15"H) furnished with spring hinges, padlock hasps, and knockout for cylinder lock.  
 With two vises **Model L5-2V**  
 With one vise **Model L5-1V**  
 Without vises **Model L5-0V**

**L5A Series**

Base contains six locker openings (18"W x 21"D x 10"H) furnished with spring hinges, padlock hasps, and knockout for cylinder lock.  
 With two vises **Model L5A-2V**  
 With one vise **Model L5A-1V**  
 Without vises **Model L5A-0V**

**L5B Series**

Includes four locker openings (18"W x 21"D x 15"H), spring hinges, padlock hasps and provisions for cylinder locks.  
 With two vises **Model L5B-2V**  
 With one vise **Model L5B-1V**  
 Without vises **Model L5B-0V**

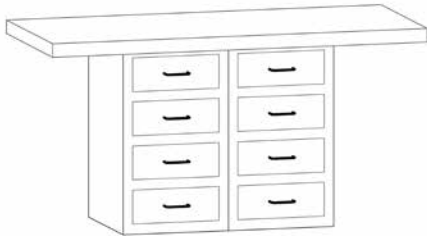

**SB5 Series**

Includes eight drawers (14-3/4"W x 19-1/2"D x 5-5/8"H) on rollers; with pulls and knockout for cylinder locks.  
 With two vises **Model SB5-2V**  
 With one vise **Model SB5-1V**  
 Without vises **Model SB5-0V**

**SB6 Series**

Includes cabinet with door, adjustable shelf, four drawers (14-3/4"W x 19-1/2"D x 5-5/8"H) with nylon rollers, pulls, padlock hasp and knockout for cylinder locks.  
 With two vises **Model SB6-2V**  
 With one vise **Model SB6-1V**  
 Without vises **Model SB6-0V**

**SB7 Series**

Base is furnished with four small drawers (14-3/4"W x 19-1/2"D x 5-5/8"H) and two larger drawers (14-3/4"W x 19-5/8"D x 13-1/4"H).  
 With two vises **Model SB7-2V**  
 With one vise **Model SB7-1V**  
 Without vises **Model SB7-0V**

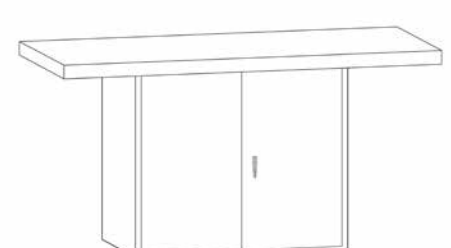
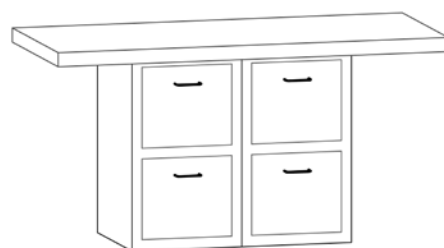
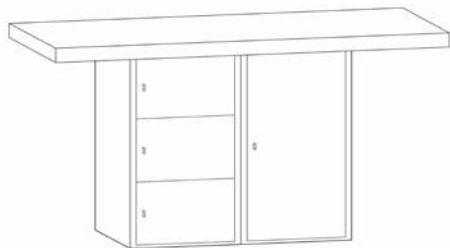

**SB9 Series**

Includes cabinet area 18"W with door, adjustable shelf and padlock hasp. Also furnished with three lockers (18"W x 21"D x 10"H) with padlock hasps, and knockout for cylinder locks.  
 With two vises **Model SB9-2V**  
 With one vise **Model SB9-1V**  
 Without vises **Model SB9-0V**

**FD5 Series**

Includes four file drawers (14-3/4"W x 19-5/8"D x 13-1/4"H) on rollers; with pull, padlock hasp and knockout for cylinder lock.  
 With two vises **Model FD5-2V**  
 With one vise **Model FD5-1V**  
 Without vises **Model FD5-0V**

**DD5 Series**

Base unit includes full size storage area, adjustable shelf and master keyed locking handle.  
 With two vises **Model DD5-2V**  
 With one vise **Model DD5-1V**  
 Without vises **Model DD5-0V**

### Four Station Workbenches

Hann's four station work benches feature specially constructed maple tops to withstand everyday, rugged use. These models include two gray base units placed back-to-back. Other colors are available. Base units are available in a variety of styles to suit your specific requirements. The overall size is 64"W x 54"D x 33-1/4"H. Available with or without vises.



#### Tops

Tops are constructed from selected northern hard maple. Natural finish. Overall top size is 64"W x 54"D x 2-1/4" thick.

#### Base Units

Bases are constructed of heavy gauge steel with welded seams throughout. Optional locks are keyed individually from the same master key series. Shipped fully assembled. Overall base size is 36"W x 21"D x 31"H.

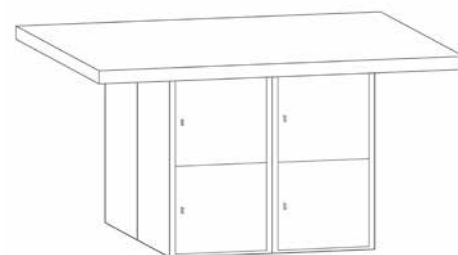
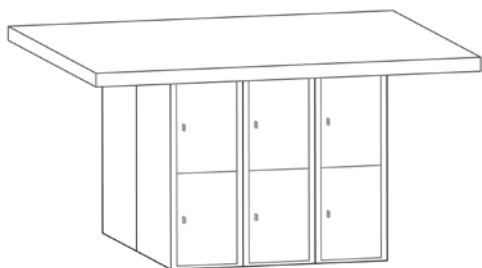

#### L4 Series

This workbench features two steel base units with six locker openings each (12"W x 21"D x 15"H) for 12 locker openings. Each door has spring hinges, padlock hasp, and knockout for cylinder lock.

Bench with four vises      **Model L4-4V**  
 Bench without vises      **Model L4-0V**

#### L4A Series

Both bases contain six locker openings (18"W x 21"D x 10"H). Locker doors include spring hinges, padlock hasp and knockout for cylinder lock.

Bench with four vises      **Model L4A-4V**  
 Bench without vises      **Model L4A-0V**

#### L4B Series

Each of the two steel base units include four large locker openings. Each of the eight locker openings measure 18"W x 21"D x 15"H. Complete with spring hinges, padlock hasp and knockout for cylinder lock.

Bench with four vises      **Model L4B-4V**  
 Bench without vises      **Model L4B-0V**

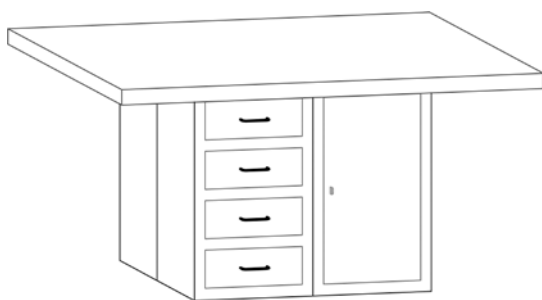

#### LU4B Series

Two steel base cabinets are equipped with storage cabinet and four drawers (14-3/4"W x 19-1/2"D x 5-5/8"H). Drawers include pull and knockout for cylinder lock and operate on nylon rollers. Steel panel above each drawer provides full security. Cabinet size is 18"W x 21"D x 31"H and includes a single door with padlock hasp, knockout for cylinder lock, spring hinges and adjustable shelf.

Bench with four vises      **Model LU4B-4V**  
 Bench without vises      **Model LU4B-0V**

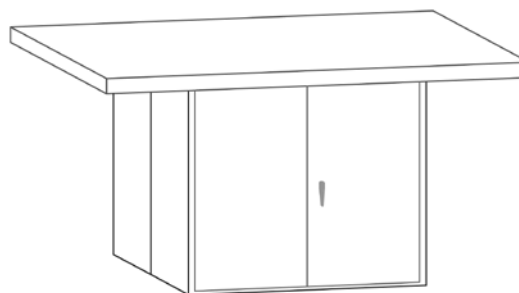

#### DD4 Series

Provides large storage capacity. Includes two steel base units with full size doors fitted with master keyed locking handle and adjustable interior shelf. Base units are 36"W x 21"D x 31"H.

Bench with four vises      **Model DD4-4V**  
 Bench without vises      **Model DD4-0V**

## Wall Assembly Units

Steel base units are available in a variety of configurations to suit your specific requirements. Maple tops, 2-1/4" or 1-3/4" thick, are constructed of the highest quality northern grown hard maple. Strips of lumber are electronically laminated with a special tight bonding glue. Tops are finished natural. Bench height is 31" plus the thickness of the top.

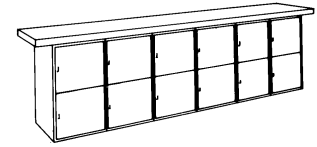
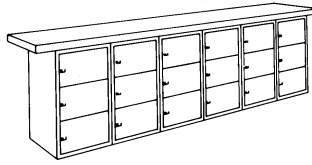

### W Series

The W series wall assembly units include model L-5 series lockers. Each locker measures (12"W x 21"D x 15"H) and is equipped with spring hinges, padlock hasp, and provision for cylinder lock. Optional cylinder locks are available.

Top Size	2-1/4" Top	1-3/4" Top
24" x 72", 10 openings.	<b>W-6</b>	<b>W-6L</b>
24" x 96", 14 openings.	<b>W-8</b>	<b>W-8L</b>
24" x 120", 18 openings.	<b>W-10</b>	<b>W-10L</b>
24" x 144", 22 openings.	<b>W-12</b>	<b>W-12L</b>

### WA Series

The WA series utilizes model L-5A series lockers which provide extra shelf storage. Each locker (18"W x 21"D x 10"H) includes spring hinges, padlock hasp and provision for cylinder lock. Optional cylinder locks available.

Top Size	2-1/4" Top	1-3/4" Top
24" x 72", 9 openings.	<b>WA-6</b>	<b>WA-6L</b>
24" x 96", 15 openings.	<b>WA-8</b>	<b>WA-8L</b>
24" x 120", 18 openings.	<b>WA-10</b>	<b>WA-10L</b>
24" x 144", 21 openings.	<b>WA-12</b>	<b>WA-12L</b>

### WB Series

The WB wall units utilize the model L-5B series base cabinet. Each locker (18"W x 21"D x 15"H) includes spring hinges, padlock hasp and provision for cylinder lock.

Top Size	2-1/4" Top	1-3/4" Top
24" x 72", 6 openings.	<b>WB-6</b>	<b>WB-6L</b>
24" x 96", 10 openings.	<b>WB-8</b>	<b>WB-8L</b>
24" x 120", 12 openings.	<b>WB-10</b>	<b>WB-10L</b>
24" x 144", 16 openings.	<b>WB-12</b>	<b>WB-12L</b>

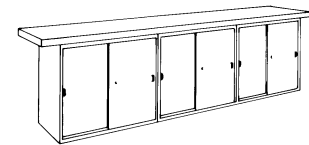
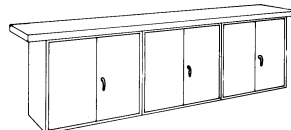

### WFD Series

The WFD series utilizes the FD-1 (18"W x 21"D x 31"H) and DD-1 units. The FD-1 includes four drawers (14-3/4"W x 19-1/2"D) mounted on nylon rollers. The DD-1 single door cabinet is supplied with adjustable shelf. Base units include padlock hasp and provision for cylinder lock. Master keyed locks optional.

Top Size	2-1/4" Top	1-3/4" Top
24" x 72", (3) FD-1, (1) DD-1.	<b>WFD-6</b>	<b>WFD-6L</b>
24" x 96", (3) FD-1, (2) DD-1.	<b>WFD-8</b>	<b>WFD-8L</b>
24" x 120", (4) FD-1, (2) DD-1.	<b>WFD-10</b>	<b>WFD-10L</b>
24" x 144", (5) FD-1, (3) DD-1.	<b>WFD-12</b>	<b>WFD-12L</b>

### WDD Series

This series features the model DD-5 base unit. It is a double door cabinet that includes master keyed locking handle and adjustable center shelf. Each cabinet is 36"W x 21"D x 31"H.

Top Size	2-1/4" Top	1-3/4" Top
24" x 72", 2 bases.	<b>WDD-6</b>	<b>WDD-6L</b>
24" x 96", 2 bases.	<b>WDD-8</b>	<b>WDD-8L</b>
24" x 108", 3 bases.	<b>WDD-9</b>	<b>WDD-9L</b>
24" x 120", 3 bases.	<b>WDD-10</b>	<b>WDD-10L</b>
24" x 144", 4 bases.	<b>WDD-12</b>	<b>WDD-12L</b>

### WSD Series

The WSD series uses the model SD-5 base. These bases include double sliding doors, master keyed lock and adjustable center shelf. Each base is 36"W x 21"D x 31"H.

Top Size	2-1/4" Top	1-3/4" Top
24" x 72", 2 bases.	<b>WSD-6</b>	<b>WSD-6L</b>
24" x 96", 2 bases.	<b>WSD-8</b>	<b>WSD-8L</b>
24" x 108", 3 bases.	<b>WSD-9</b>	<b>WSD-9L</b>
24" x 120", 3 bases.	<b>WSD-10</b>	<b>WSD-10L</b>
24" x 144", 4 bases.	<b>WSD-12</b>	<b>WSD-12L</b>



**Woodworking Bench**

This sturdy bench includes a heavy maple top (54"W x 22"D x 2-1/4" thick), one woodworking vise and a storage drawer (30"W x 16"D x 6"H). Overall height is 32".

**Model G-1**

The G-2 is similar to the G-1 without the large storage drawer.

**Model G-2**



**Woodworking Bench**

The G-22 includes large 54"W x 36"D x 2-1/4" thick laminated maple top. Base is furnished with two drawers (30"W x 16"D x 6"H), and two woodworking vises. Overall height is 32".

**Model G-22**



**Woodworking Bench**

This two station workbench is furnished with two large drawers (22-1/2"W x 14"D x 4"H), eight smaller drawers (9-1/2"W x 14"D x 4"H) and two woodworking vises. Laminated maple top is 2-1/4" thick x 54"W x 36"D. Overall height is 32".

**Model G-44**



**Mitre Saw Bench**

Constructed to accommodate a miter saw in the center step down area. Outer tops are 1-3/4" thick laminated maple 23"W x 24"D each. The step down miter area is 26"W x 21-1/2"D. Legs are of 2-1/4" square maple bolted construction. Stringers are 1-3/4"W x 3"D. Bottom center rail is ideal for mounting C-clamps, etc. Assembly hardware included. Mitre saw not included. Natural finish.

**Model M2-OB**



**Glue Clamp Table**

A specially designed table to accept bar clamps and to provide an area for gluing of projects and clamp storage. Complete with galvanized drip pan. Open top includes 17 sets of notches which accept bar clamps 3' and over. The notches, positioned 3-3/4" apart, are cut into heavy 12 gauge steel rail. The entire table is heavy duty maple with natural finish. Legs are 2-1/4" square. Stringers and rails are 1-3/4" x 3" with bolted joints. Overall table size is 72"W x 36"D x 32"H.

**Model GC-4**

Similar to the GC-4, only without the drip pan.

**Model GC-2**



**Glue and Stain Bench**

This bench provides a sturdy work center for finishing projects. The base is constructed of hard maple solids with a lower plywood storage shelf. Top is galvanized steel. Overall size is 60"W x 24"D x 32"H.

**Model GS-24**

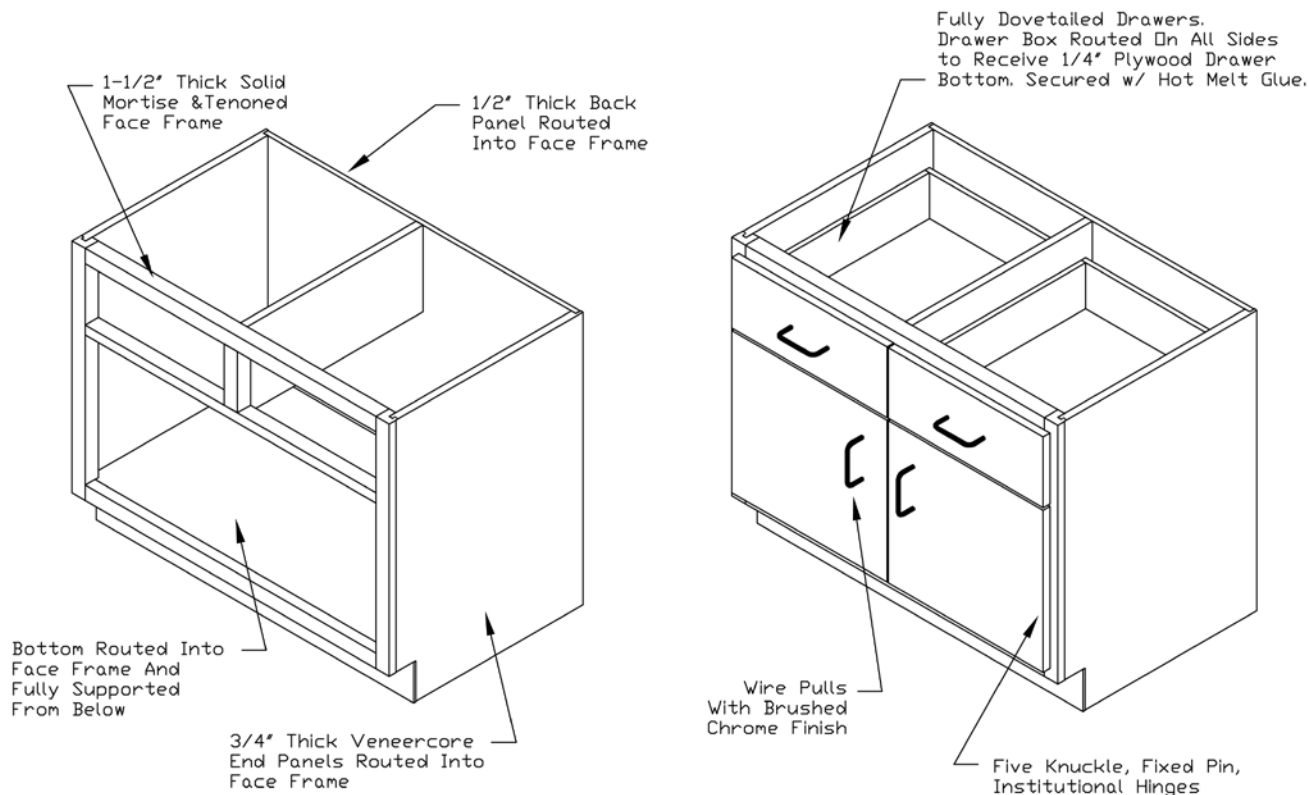

**Materials & Finish**

All of our cabinets are made from solid hard maple framing and maple veneercore plywood as standard. However, most all of our products are also available in red oak - ask us for details.

Our products receive a natural finish as standard. Stained finishes can also be offered upon request - ask us for details.

**Lumber.** Only selected hard maple or red oak, kiln-dried to 6% - 8% moisture content is used on exposed surfaces. Sound kiln-dried hardwood is used on unexposed surfaces and other framing, etc.

**Plywoods** shall be of thickness and with number of plies as specified. Face veneer shall be standard thickness. Balanced crossband construction.

**Construction**

**Base Cabinets**

Base cabinets shall have 1-1/2" thick solid hard maple face frames with stiles and cross members mortised and tenoned, glue and stapled securely together. Face frames are routed to accept 3/4" veneercore end panels and bottom. End panels are routed to accept 1/2" back. Bottoms are fully supported from underneath. All members are glued and stapled to one another forming a strong, interconnected cabinet. No construction hardware is exposed on the front frame. End panels are slightly recessed into the frame to ensure flush frontal appearance. Adjustable shelves shall be 3/4" or 1" veneercore plywood.

**Wall Cabinets**

Wall cabinets shall have 1-1/2" thick solid hard maple face frames with stiles and cross members mortised and tenoned, glued and stapled securely together. Face frames are routed to accept 3/4" veneercore end panels, top, and bottom. End panels are routed to accept top, bottom, and 1/2" back. Bottoms additionally supported by solid rear cleat. Solid mounting cleat provided at upper back of cabinet. All members are glued and stapled to one another forming a strong, interconnected cabinet. No construction hardware is exposed on the front frame. End panels are slightly recessed into the frame to ensure flush frontal appearance. Adjustable shelves shall be 3/4" or 1" veneercore plywood.

**Tall Cabinets**

Tall cabinets shall have 1-1/2" thick solid hard maple face frames with stiles and cross members mortised and tenoned, glued and stapled securely together. Face frames are routed to accept 3/4" veneercore end panels, top, and bottom. End panels are routed to accept top and 3/4" back. Bottoms are fully supported from underneath. All members are glued and stapled to one another forming a strong, interconnected cabinet. No construction hardware is exposed on the front frame. End panels are slightly recessed into the frame to ensure flush frontal appearance. Adjustable shelves shall be 3/4" or 1" veneercore plywood.

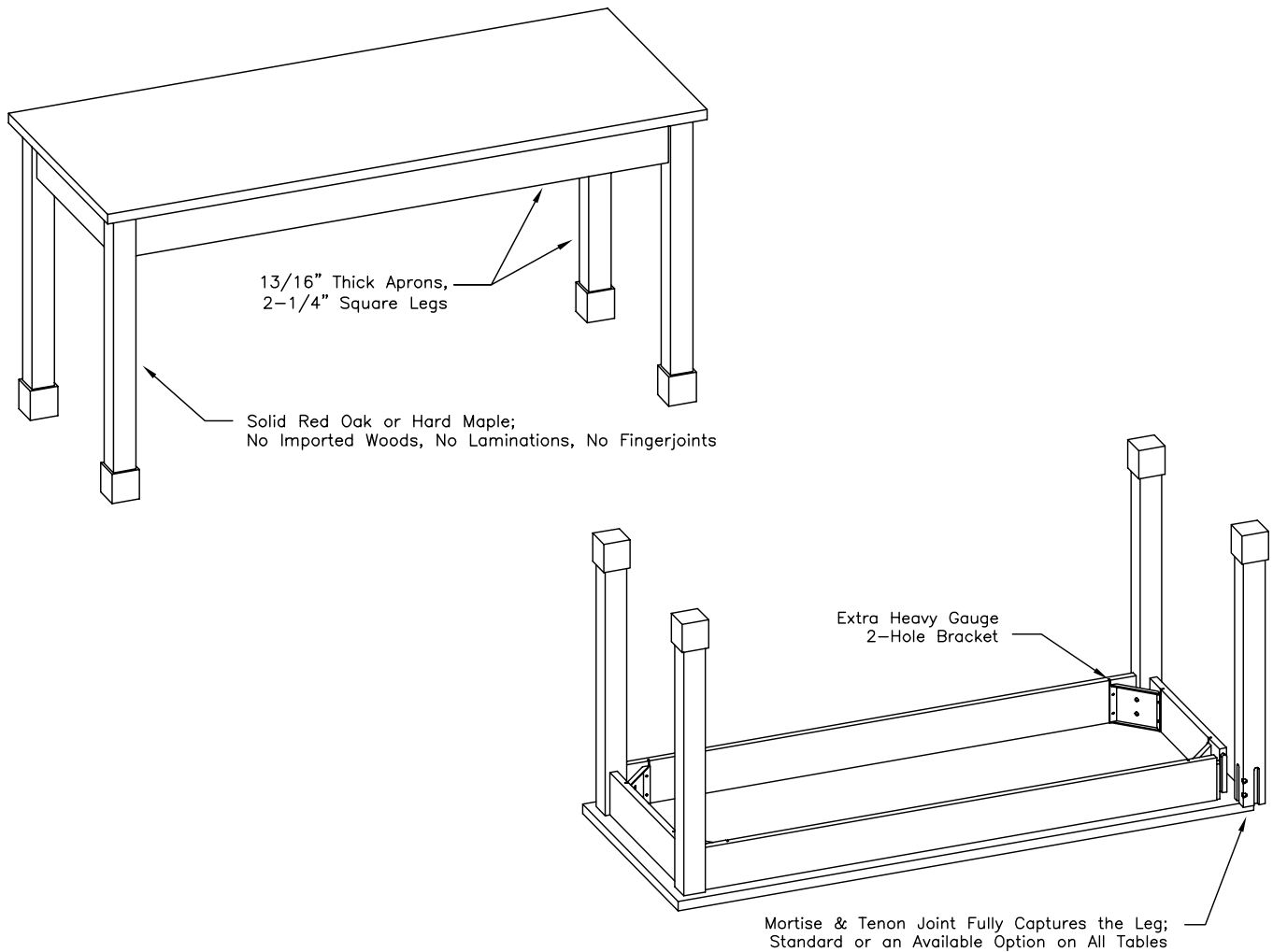

### Materials & Finish

All of our tables are made from solid domestic hard maple or red oak. No imported or finger-jointed wood shall be used.

Our products receive a natural finish as standard. Stained finishes can also be offered upon request - ask us for details.

**Lumber.** Only selected hard maple or red oak, kiln-dried to 6% - 8% moisture content is used on exposed surfaces. Sound kiln-dried hardwood is used on unexposed surfaces and other framing, etc.

### Construction

#### Science Tables

Aprons shall be 13/16" thick and 4-1/2" high. Legs shall be 2-1/4" square. Legs will be secured to aprons via an extra heavy gauge 2-hole steel corner bracket. Two Grade 5 bolts per bracket will be inserted into heavy-duty steel inserts in the leg for a metal-to-metal connection. Optional mortise and tenon joints shall be machined so that the leg is fully captured when slid onto the apron tenons which would prevent the leg from failing should someone intentionally loosen/remove the bolts. Optional lower leg spreaders shall be 1-1/4" thick. Legs shall include protective boots and adjustable glides. Table tops shall be attached to the aprons at the factory prior to shipment.

**NOTE:** All specifications are subject to change without notice.

2022.10

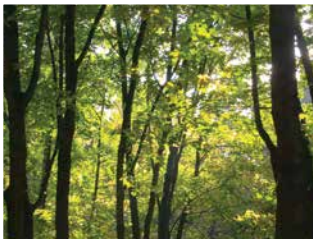
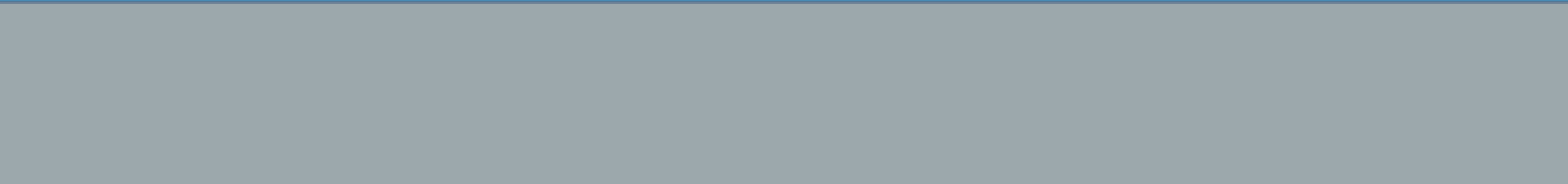

740.962.4885

[www.hannmfg.com](http://www.hannmfg.com)



Hann - made  
in the USA